



The precision instrument for high speed inspection

USER MANUAL

AViiVA

e2v.com/imaging

WE PARTNER WITH OUR CUSTOMERS TO IMPROVE, SAVE AND PROTECT PEOPLE'S LIVES



Table of Contents

1 CAMERA OVERVIEW	5
1.1 Features	5
1.2 Key Specifications	5
1.2.1 Machine Vision Versions (BA0).....	5
1.2.2 OCT/Spectrometer versions (BA9)	6
1.2.3 Common Characteristics.....	6
1.3 Description.....	7
1.4 Typical Applications	7
1.5 Models	7
2 CAMERA PERFORMANCES	8
2.1 Camera Characterization	8
2.1.1 Machine Vision Versions (BA0).....	8
2.1.2 OCT Versions (BA9).....	8
3 Image Sensor	9
3.1 Response & QE curves	10
3.1.1 Quantum Efficiency	10
3.1.2 Spectral Response	10
4 CAMERA HARDWARE INTERFACE.....	11
4.1 Mechanical Drawings.....	11
4.2 Input/output Connectors and LED.....	13
4.3 Status LED Behaviour.....	14
4.3.1 Power Connector	14
4.4 CameraLinkOutputConfiguration	15
4.4.1 AVIIVA EM2.....	15
4.4.2 AVIIVA EM4.....	15
5 STANDARD CONFORMITY	17
5.1 CE Conformity	17
5.2 FCC Conformity	17
5.3 RoHs Conformity	17
6 GETTING STARTED	18

6.1 Out of the box.....	18
6.2 Setting up in the system	19
7 CAMERA SOFTWARE INTERFACE.....	20
7.1 Control and Interface	20
7.2 Serial Protocol and Command Format	21
7.2.1 Syntax	21
7.2.2 Command Processing	21
7.2.3 GenICam ready	21
8 Camera Commands	22
8.1 Information.....	22
8.2 Dump and Communication.....	23
8.3 Status, Temperature & Standby	24
8.4 Image Format	25
8.5 Exposure and Synchronization	27
8.5.1 Timing Specifications	27
8.6 Gain and Offset.....	33
8.6.1 Analog Gain.....	34
8.6.2 Tap Balance.....	35
8.6.3 Contrast Expansion.....	37
8.7 Flat Field Correction	38
8.7.1 Activation, Filter and Auto-Adjust	39
8.7.2 Automatic Calibration.....	41
8.7.3 Manual Flat Field Correction	42
8.7.4 FFC User Bank Management	43
8.8 Look Up Table	44
8.9 Statistics and Line Profile.....	46
8.10 Privilege Level.....	47
8.11 Save & Restore Settings.....	48
APPENDIX	49
Appendix A. Test Patterns	50
A.1 Test Pattern 1 : Vertical wave	50
A.2 Test Pattern 2 : In 8 bits format	50
A.1.2 512 Pixels.....	50
A.2.2 1024 Pixels.....	50

A.3.2 2048 Pixels.....	51
A.4.2 4096 Pixels.....	51
A.3 Test Pattern 2 : In 12 bits format	52
A.1.3 512 Pixels.....	52
A.2.3 1024 Pixels.....	52
A.3.3 2048 Pixels.....	53
A.4.3 4096 Pixels.....	53
Appendix B. Thermal Management	54
B.1 Heat Sinks	54
B.2 Temperature dropping	55
B.3 Performance curves versus Temperature	56
Appendix C. Optical Mounts available	58
C.1 F-Mount.....	58
C.2 C-Mount.....	59
C.3 T2 & M42x1 Mounts.....	60
Appendix D. CommCam Connection	61
Appendix E. COMMAND SUMMARY	63
E.1 Information.....	63
E.2 Dump and Communication.....	63
E.3 Standby, Temperature and Status.....	63
E.4 Image Format.....	64
E.5 Exposure and Synchronization	64
E.6 Gain and Offset.....	65
E.7 Flat Field Correction	66
E.8 Look up Table.....	67
E.9 Statistics and Line Profile.....	67
E.10 Privilege Level	68
E.11 Save & Restore Settings.....	68
Appendix F. Revision History	69

1 CAMERA OVERVIEW

1.1 Features

- Sensor :
 - 512 14x14µm or 1024 14x14µm or 2048 14x14µm or 4096 10x10µm pixels for Machine Vision versions (BA0)
 - 1024 14x28µm or 2048 10x20µm or 2048 14x28µm pixels for OCT/Spectrometer Versions (BA9)
- Interface : CameraLink® Base for EM2, Base/Medium for EM4
- Data rate :
 - EM2 : 80MPixels/s
 - EM4 : 160MPixels/s
- Bit Depth : 12,10 or 8 bits
- 100% Aperture, Built-in Anti-blooming, No Lag
- Automatic tap balance and FlatField correction
- Contrast expansion
- Look Up Table
- Standby low power mode
- Statistic functions on ROI
- Very compact design : 93 x 56 x 43 mm (w, h, d)
- Fully configurable with e2v's CommCam UCL software.

1.2 Key Specifications

Note : All values in LSB is given in 12 bits format

1.2.1 Machine Vision Versions (BA0)

Characteristics	Typical Value				Unit
Sensor Characteristics at Maximum Pixel Rate					
Resolution	512	1024	2048	4096	Pixels
pixel size (square)	14x14	14x14	14x14	10x10	µm
Max line rate – EM4 (4 Taps)	210	126	70.79	37.14	kHz
Max line rate – EM2 (2 Taps)	126	70	37.14	19.04	
Radiometric Performance at Maximum Pixel Rate and minimum camera gain					
Bit depth	8, 10, 12				Bits
Response (broadband)	164	164	164	82	LSB/(nJ/cm ²)
Full Well Capacity	117500				electrons
Response non linearity	0,05				%
PRNU	1				%
Dynamic range	68				dB

1.2.2 OCT/Spectrometer versions (BA9)

Characteristics	Typical Value			Unit
Sensor Characteristics at Maximum Pixel Rate				
Resolution	1024	2048	2048	Pixels
pixel size (square)	14x28	14x28	10x20	µm
Max line rate – EM4 (4 Taps)	126	70.79	70.79	kHz
Max line rate – EM2 (2 Taps)	70	37.14	37.14	
Radiometric Performance at Maximum Pixel Rate and minimum camera gain				
Bit depth	8, 10, 12			Bits
Response (at 840nm)	120	120	78	LSB/(nJ/cm ²)
Full Well Capacity	238	312	238	Ke-
Response non linearity	0,05			%
PRNU	1			%
Dynamic range	70			dB
Power Spectral Density(*)	< 20			-

(*) Power Spectral Density is a specific test for BA9 version. Contact Hotline for more info.

1.2.3 Common Characteristics

Functionality (Programmable via Control Interface)		
Gain	Up to 32	dB
Offset	-4096 to +4096	LSB
Trigger Mode	Timed (Free run) and triggered (Ext Trig, Ext ITC) modes	
Mechanical and Electrical Interface		
Size (w x h x l)	93 x 56 x 43 with lateral heatsinks 60 x 56 x 43 without lateral heatsinks	mm
Weight	310 (without mount but includes lateral heatsinks)	g
Lens Mount	F, T2, M42x1 compliant with AVIIVA SM2 series	
Sensor alignment (see chapter 4)	±100	µm
Sensor flatness	±35	µm
Power supply	Single 12 DC to 24 DC	V
Power dissipation	< 11	W
Low power mode	< 4	
General Features		
Operating temperature	0 to 55 (front face) or 70 (Internal)	°C
Storage temperature	-40 to 70	°C
Regulatory	CE, FCC and RoHS compliant	

1.3 Description

The AVIIVA EM2/EM4 is designed to set new standards for line scan cameras in term of speed and image quality. With resolutions of up to 4096 pixels, and the design of new CCD image sensors, it delivers state of the art performance, without compromises.

Its rich built-in features, such as automatic FCC, LUT or automatic tap balance, are positioning it as the perfect choice for high demanding Machine Vision Applications (BA0)

A specific rectangular-pixels sensor version (BA9) is dedicated to specific applications as Optical Coherence Tomography (OCT) or Spectrometer.

The EM2/EM4 benefits from e2v's long experience in imaging, and the proven qualities of the Aviiva family : performances, reliability, and high precision mechanical design.

1.4 Typical Applications

- Web Inspection : metallurgy, wood, paper, textile ...
- Process control : pick and place, positioning
- Print Inspection
- Sorting : food, postal, parcel, checks, ...
- Surface inspection : wafers, PCB, ...
- Document archiving, data archiving
- OCR and barcode reading
- OCT/Spectrometer for **BA9** versions.

1.5 Models

Part Number	Sensor	Outputs	Max Line Rate
Machine Vision versions			
EV71YEM4CL4010-BA0	4k x 10µm	4x40MHz or 2x80MHz	37 KHz
EV71YEM4CL2014-BA0	2k x 14µm	4x40MHz or 2x80MHz	70 KHz
EV71YEM4CL1014-BA0	1k x 14µm	4x40MHz or 2x80MHz	126 KHz
EV71YEM4CL514-BA0	0.5k x 14µm	4x40MHz or 2x80MHz	210 KHz
EV71YEM2CL4010-BA0	4k x 10µm	2x40MHz	19 KHz
EV71YEM2CL2014-BA0	2k x 14µm	2x40MHz	37 KHz
EV71YEM2CL1014-BA0	1k x 14µm	2x40MHz	70 KHz
EV71YEM2CL514-BA0	0.5k x 14µm	2x40MHz	126 KHz
OCT/Spectrometer versions			
EV71YEM4CL2010-BA9	2k 10µmx20µm	4x40MHz or 2x80MHz	70 KHz
EV71YEM4CL2014-BA9	2k 14µmx28µm	4x40MHz or 2x80MHz	70 KHz
EV71YEM4CL1014-BA9	1k 14µmx28µm	4x40MHz or 2x80MHz	126 KHz
EV71YEM2CL2010-BA9	2k 10µmx20µm	2x40MHz	37 KHz
EV71YEM2CL2014-BA9	2k 14µmx28µm	2x40MHz	37 KHz
EV71YEM2CL1014-BA9	1k 14µmx28µm	2x40MHz	70 KHz

2 CAMERA PERFORMANCES

2.1 Camera Characterization

2.1.1 Machine Vision Versions (BA0)

	Unit	Min Gain (-24dB)			Av. Gain (-12dB)			Max Gain (0dB)		
		Min	Typ.	Max	Min	Typ.	Max	Min	Typ.	Max
Dark Noise RMS	LSB	-	1,6	2,6		6,4			27	-
Dynamic Range	-	-	2730:1	-	-	635:1	-	-	160:1	-
SNR	dB	-	48	-	-	42	-	-	35	-
Light RMS Noise	LSB		11,1							
Non Linearity	%		±0,3	±1		±0,5			±0,10	
Without Flat Field Correction – Half saturation										
FPN rms	LSB		0,3	2	-	1	-	-	4	-
FPN peak-peak	LSB	-	2	7	-	7	-	-	30	
PRNU hf	%	-	0,2	0,5	-	0,2	-	-	0,2	-
PRNU peak-peak	%	-	1	3	-	1,5	-	-	1,8	-
With Flat Field Correction										
PRNU hf	LSB	-	0,7	2	-	1,5	-	-	3,4	-
PRNU peak-peak	LSB	-	5	-	-	10,5	-	-	24	-

2.1.2 OCT Versions (BA9)

	Unit	Min Gain (-24dB)			Av. Gain (-12dB)			Max Gain (0dB)		
		Min	Typ.	Max	Min	Typ.	Max	Min	Typ.	Max
Dark Noise RMS	LSB	-	1,3	2,6		6,4			27	-
Dynamic Range	-	-	3150:1	-	-	635:1	-	-	160:1	-
Light RMS Noise	LSB		7,7							
SNR	dB	-	48	-	-	42	-	-	35	-
Non Linearity	%		±0,3	±1		±0,5			±0,10	
Without Flat Field Correction – Half saturation										
FPN rms	LSB		0,3	2	-	1	-	-	4	-
FPN peak-peak	LSB	-	2	7	-	7	-	-	30	
PRNU hf	%	-	0,2	0,5	-	0,2	-	-	0,2	-
PRNU peak-peak	%	-	1	3	-	1,5	-	-	1,8	-
With Flat Field Correction										
PRNU hf	LSB	-	0,7	2	-	1,5	-	-	3,4	-
PRNU peak-peak	LSB	-	5	-	-	10,5	-	-	24	-

Test conditions :

- Figures in LSB are for a 12bits format.
- Measured at exposure time = 100µs and line period = 100µs
- Maximum data rate (4 × 40 MHz)
- Light source 3200K with BG38 filter 2 mm thickness
- Stabilized temperature 30/40/55 °C (Room/Front Face/Internal)
- SNR Calculated at 75% Vsat with minimum Gain.

3 Image Sensor

The Tap structure of the sensors is the following :

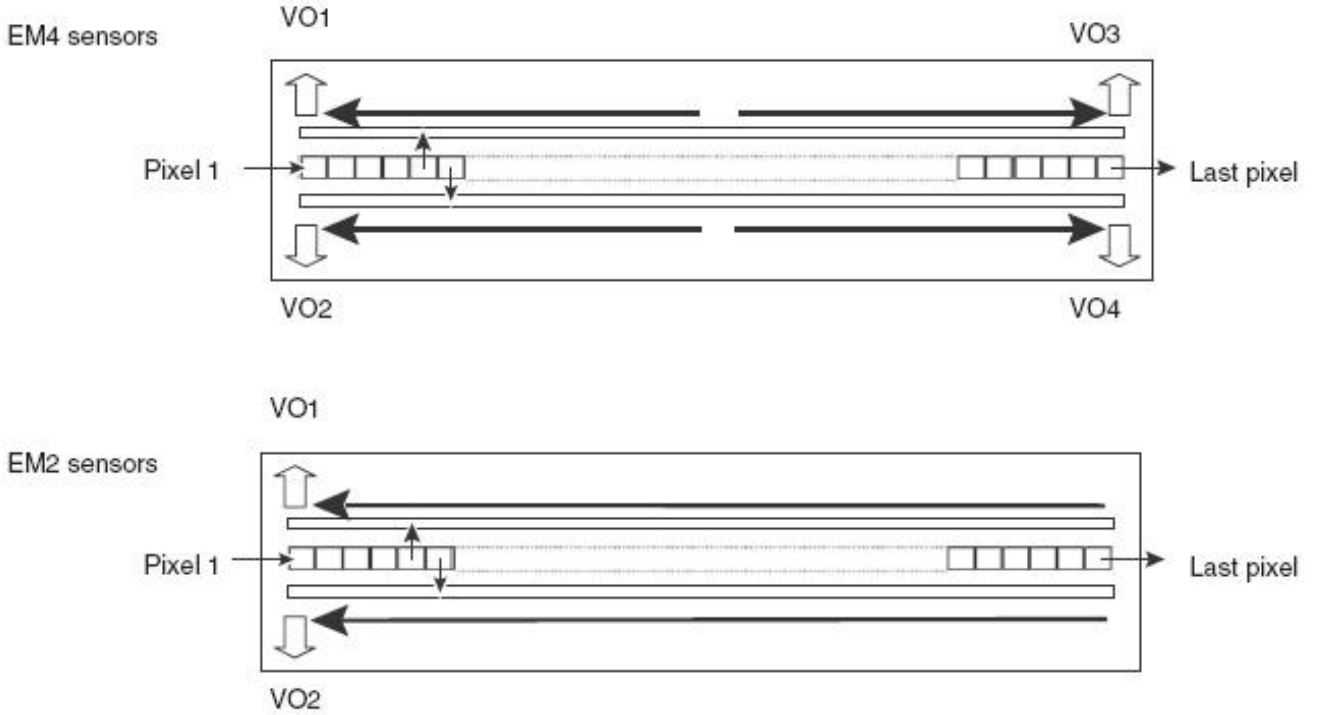

On the BA9 Versions, the pixel is rectangular in order to facilitate the positioning of the Camera in the spectrometer :

- 20 μ m height for the 10 μ m pitch.
- 28 μ m height for the 14 μ m pitch.

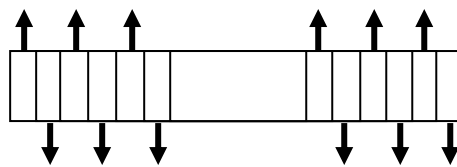

3.1 Response & QE curves

3.1.1 Quantum Efficiency

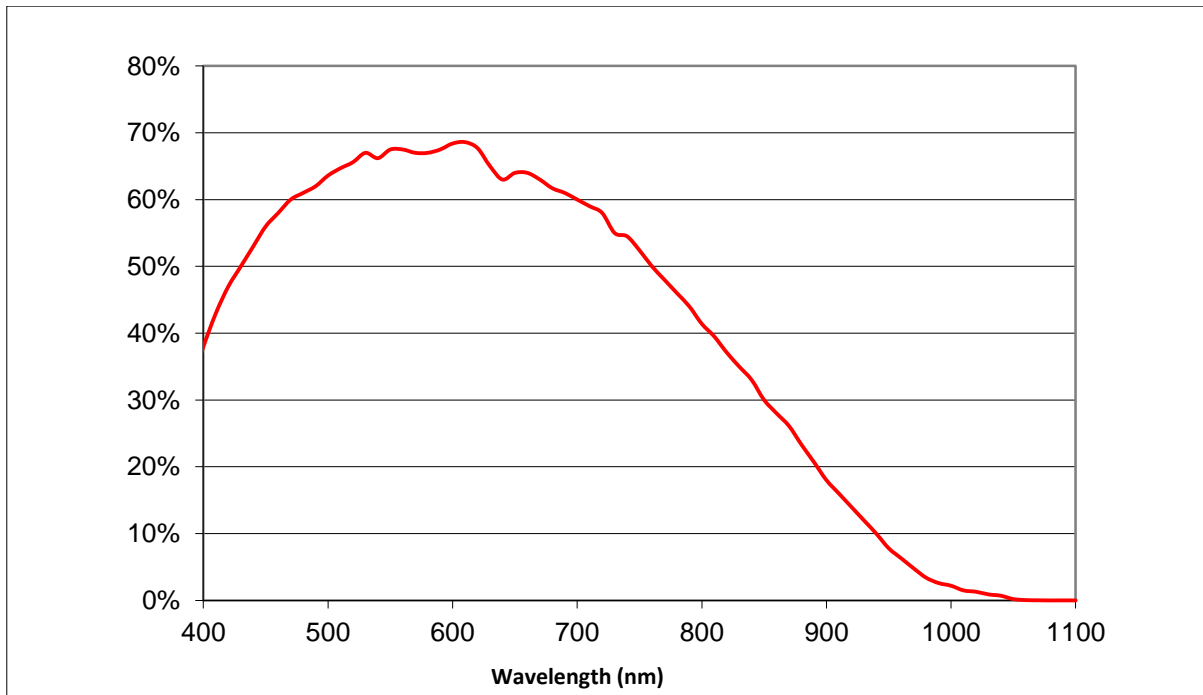

3.1.2 Spectral Response

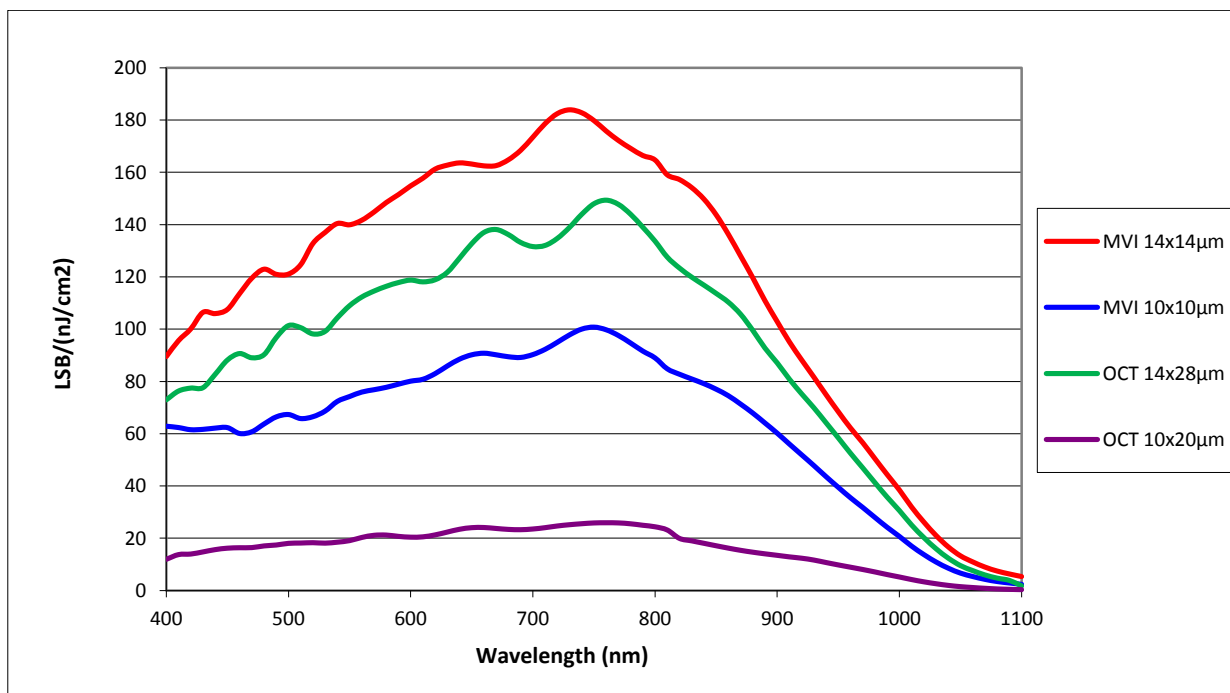

Sensor alignment		
Z = -10.3		±150µm
4k 10µm :	X = 7.52mm	±100 µm
2k 14µm :	X = 13.66mm	
2k 10µm :	X = 17,76mm	
1k 14µm :	X = 20.83mm	
512 14µm :	X = 24.41mm	
Y = 30mm		±100 µm
Planarity		±35 µm
Rotation (X,Y plan)		±0,2°
Tilt (versus lens mounting plane)		±35µm

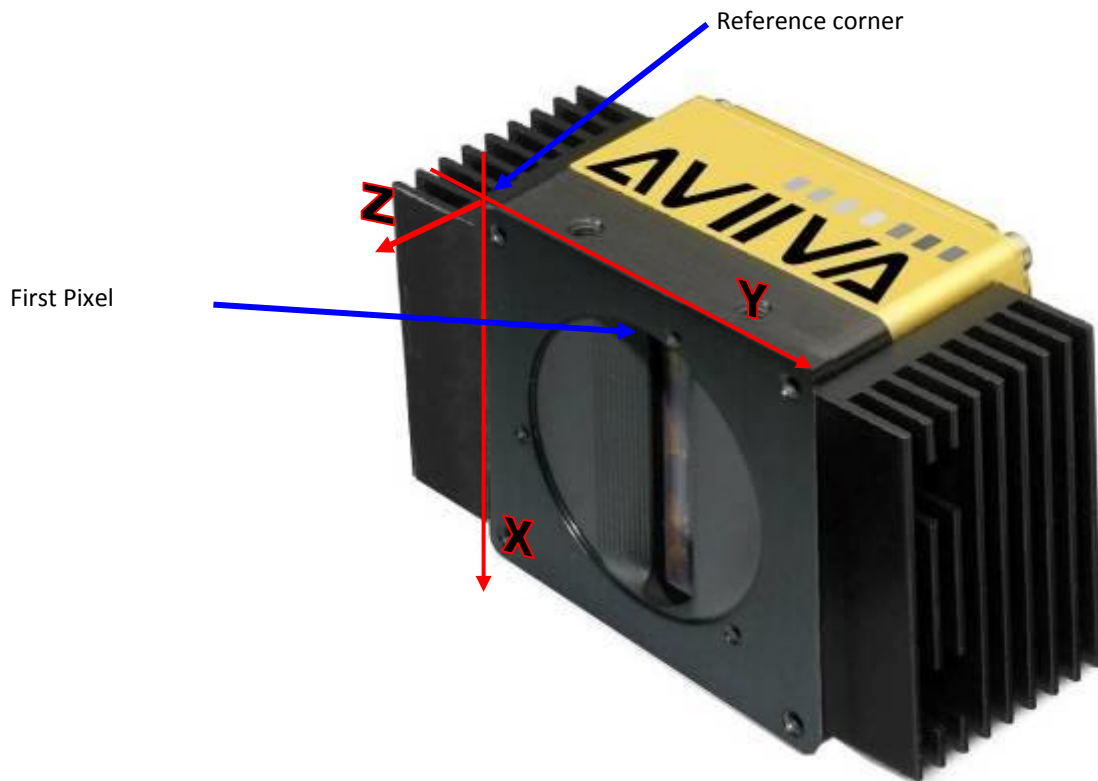

4.2 Input/output Connectors and LED



4.3 Status LED Behaviour

After less than 2 seconds of power establishment, the LED first lights up in ORANGE. Then after a Maximum of 30 seconds, the LED must turn in a following colour :

Colour and state	Meaning
Green and continuous	OK
Green and blinking slowly	Waiting for Ext Trig (Trig1 and/or Trig2)
Red and continuous	Camera out of order : Internal firmware error

4.3.1 Power Connector

Camera connector type: Hirose HR10A-7R-6PB (male)

Cable connector type: Hirose HR10A-7P-6S (female)

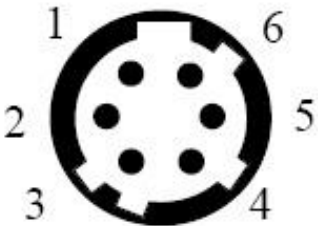
	Signal	Pin	Signal	Pin
	PWR	1	GND	4
	PWR	2	GND	5
	PWR	3	GND	6
Power supply from 12 to 24V Power 11W max with an typical inrush current peak of 2,2A during power up				

Typical values	Current consumption	
Camera	12V	24V
EM4 2kx10µm	0,71A	0,37A
EM4 2kx14µm	0,76A	0,40A
EM4 4kx10µm	0,83A	0,43A
EM4 1kx14µm	0.75A	0.38A
EM4 512x14µm	0.51A	0.26A
EM2 2kx10µm	0,50A	0,18A
EM2 2kx14µm	0,55A	0,30A
EM2 4kx10µm	0,61A	0,32A
EM2 1kx14µm	0.57A	0.29A
EM2 512x14µm	0.51A	0.26A

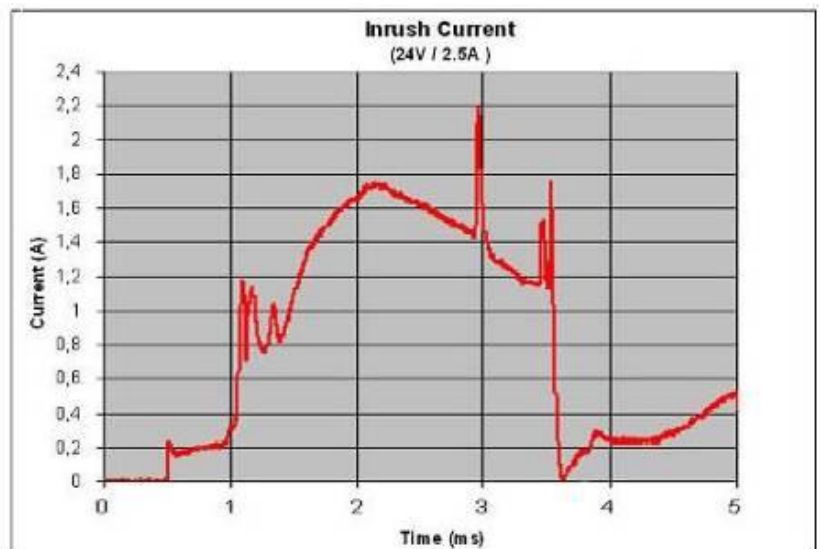

In standby mode at 24V :

- Power = around 3,7W
- Current = 0,155A

Power up Time : Around 30s

4.4 CameraLinkOutputConfiguration

4.4.1 AVIIVA EM2

Mode Base	Connector CL1
2 x Channels 8bits	2 x 40MHz odd/even
2 x Channels 10bits	2 x 40MHz odd/even
2 x Channels 12bits	2 x 40MHz odd/even

4.4.2 AVIIVA EM4

Mode	Connector CL1	Connector CL1
Base		
2 x Channels 8bits	2 x 80MHz separate divergent	-
2 x Channels 10bits	2 x 80MHz separate divergent	-
2 x Channels 12bits	2 x 80MHz separate divergent	-
Medium		
4 x Channels 8bits	CameraLink Standard Medium 4 x 8bits	
4 x Channels 10bits	CameraLink Standard Medium 4 x 10bits	
4 x Channels 12bits	CameraLink Standard Medium 4 x 12bits	

Connector CL1 assignment table: (Medium mode for EM4 only)

Port/Bit	Medium 8 bits	Medium 10bits	Medium 12bits
Port A0	A0	A0	A0
Port A1	A1	A1	A1
Port A2	A2	A2	A2
Port A3	A3	A3	A3
Port A4	A4	A4	A4
Port A5	A5	A5	A5
Port A6	A6	A6	A6
Port A7	A7	A7	A7
Port B0	B0	A8	A8
Port B1	B1	A9	A9
Port B2	B2	nc	A10
Port B3	B3	nc	A11
Port B4	B4	B8	B8
Port B5	B5	B9	B9
Port B6	B6	nc	B10
Port B7	B7	nc	B11
Port C0	C0	B0	B0
Port C1	C1	B1	B1
Port C2	C2	B2	B2
Port C3	C3	B3	B3
Port C4	C4	B4	B4
Port C5	C5	B5	B5
Port C6	C6	B6	B6
Port C7	C7	B7	B7

Connector CL2 assignment table: (EM4 only)

Port/Bit	Medium 8 bits	Medium 10bits	Medium 12bits
Port D0	D0	D0	D0
Port D1	D1	D1	D1
Port D2	D2	D2	D2
Port D3	D3	D3	D3
Port D4	D4	D4	D4
Port D5	D5	D5	D5
Port D6	D6	D6	D6
Port D7	D7	D7	D7
Port E0	nc	C0	C0
Port E1	nc	C1	C1
Port E2	nc	C2	C2
Port E3	nc	C3	C3
Port E4	nc	C4	C4
Port E5	nc	C5	C5
Port E6	nc	C6	C6
Port E7	nc	C7	C7
Port F0	nc	C8	C8
Port F1	nc	C9	C9
Port F2	nc	nc	C10
Port F3	nc	nc	C11
Port F4	nc	D8	D8
Port F5	nc	D9	D9
Port F6	nc	nc	D10
Port F7	nc	nc	D11

5 STANDARD CONFORMITY

The AVIIVA EM2/EM4 cameras have been tested using the following equipment:

- A shielded power supply cable
- A Camera Link data transfer cable ref. 14B26-SZLB-500-OLC(3M)

e2v recommends using the same configuration to ensure the compliance with the following standards.

5.1 CE Conformity

The AVIIVA EM2/EM4 cameras comply with the requirements of the EMC (European) directive 2004/108/CE (EN50081-2, EN 61000-6-2).

5.2 FCC Conformity

The AVIIVA EM2/EM4 cameras further comply with Part 15 of the FCC rules, which states that: Operation is subject to the following two conditions:

- This device may not cause harmful interference, and
- This device must accept any interference received, including interference that may cause undesired operation

This equipment has been tested and found to comply with the limits for Class A digital device, pursuant to part 15 of the FCC rules. These limits are designed to provide reasonable protection against harmful interference when the equipment is operated in a commercial environment. This equipment generates, uses and can radiate radio frequency energy and, if not installed and used in accordance with the instruction manual, may cause harmful interference to radio communications. Operation of this equipment in a residential area is likely to cause harmful interference in which case the user will be required to correct the interference at his own expense.

Warning: Changes or modifications to this unit not expressly approved by the party responsible for compliance could void the user's authority to operate this equipment.

5.3 RoHs Conformity

AVIIVA EM2/EM4 cameras comply with the requirements of the RoHS directive 2002/95/EC.

6 GETTING STARTED

6.1 Out of the box

The contents of the Camera box is the following :



Camera with
2 x Heat Sinks mounted

Power Connector



There is no CDROM delivered with the Camera : Both User Manual (this document) and CommCam control software have to be downloaded from the web site : This ensure you to have an up-to-date version.

Main Camera page : www.e2v.com/cameras

On the appropriate Camera Page (AVIIVA EM2 or EM4) you'll find a download link first version of CommCam compliant is indicated in the last Chapter

CommCam download requires a login/password :

Login : [commcam](#)

Password : [chartreuse](#)



6.2 Setting up in the system

Vocabulary :

w = size of the sensor line (40,96mm for the 4k 10µm)

FOV = Field Of View (width of the web inspected by the sensor line) in mm.

L = Working distance (from the Lens to the Web) in mm.

f = focal distance of the lens in mm.

S = Speed of the web in mm/s

We have :
$$\frac{w}{FOV} = \frac{f}{L}$$

The ratio $M = w/FOV$ is called Magnification.

The FOV is grabbed by 4096 pixels in the width.

In order to get a ratio of 1 :1 in your image, at the web speed of S, your line rate has to be set :

$$\text{Line Rate} = (S/FOV) \times 4096$$

Ex : if the FOV = 11 cm (110mm) and the speed of the web is $S = 0,3 \text{ m/s}$ (300mm/s) the line rate will be :

$$\text{Line Rate} = (300 / 110) \times 4096 = 11170 \text{ Lines/s.}$$

If you use a 60mm lens, the working distance will be : $L = (60 \times 110) / 40,96 = 161\text{mm.}$

This will certainly require a macro lens.

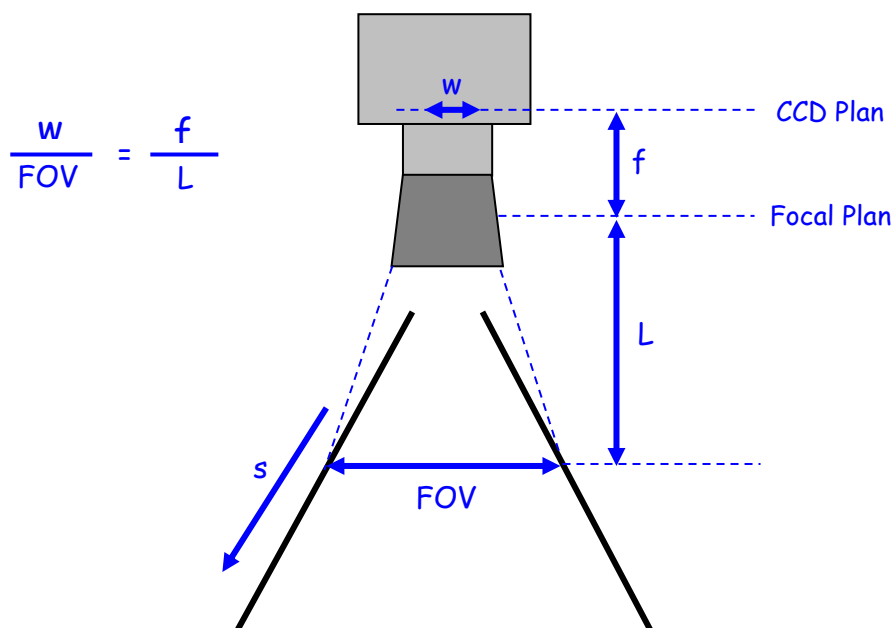

7 CAMERA SOFTWARE INTERFACE

7.1 Control and Interface

As all the e2V Cameras, the AVIIVA II is delivered with the friendly interface control software COMMCAM.UCL (as “Ultimate Camera Link”) which is based on the GenICam standard

COMMCAM recognizes and detects automatically all the UCL Cameras connected on any transport layers (Camera Link or COM ports) of your system.

Once connected to the Camera you have an easy access to all its features. The visibility of these features can be associated to three types of users: Beginner, Expert or Guru. Then you can make life easy for simple users.

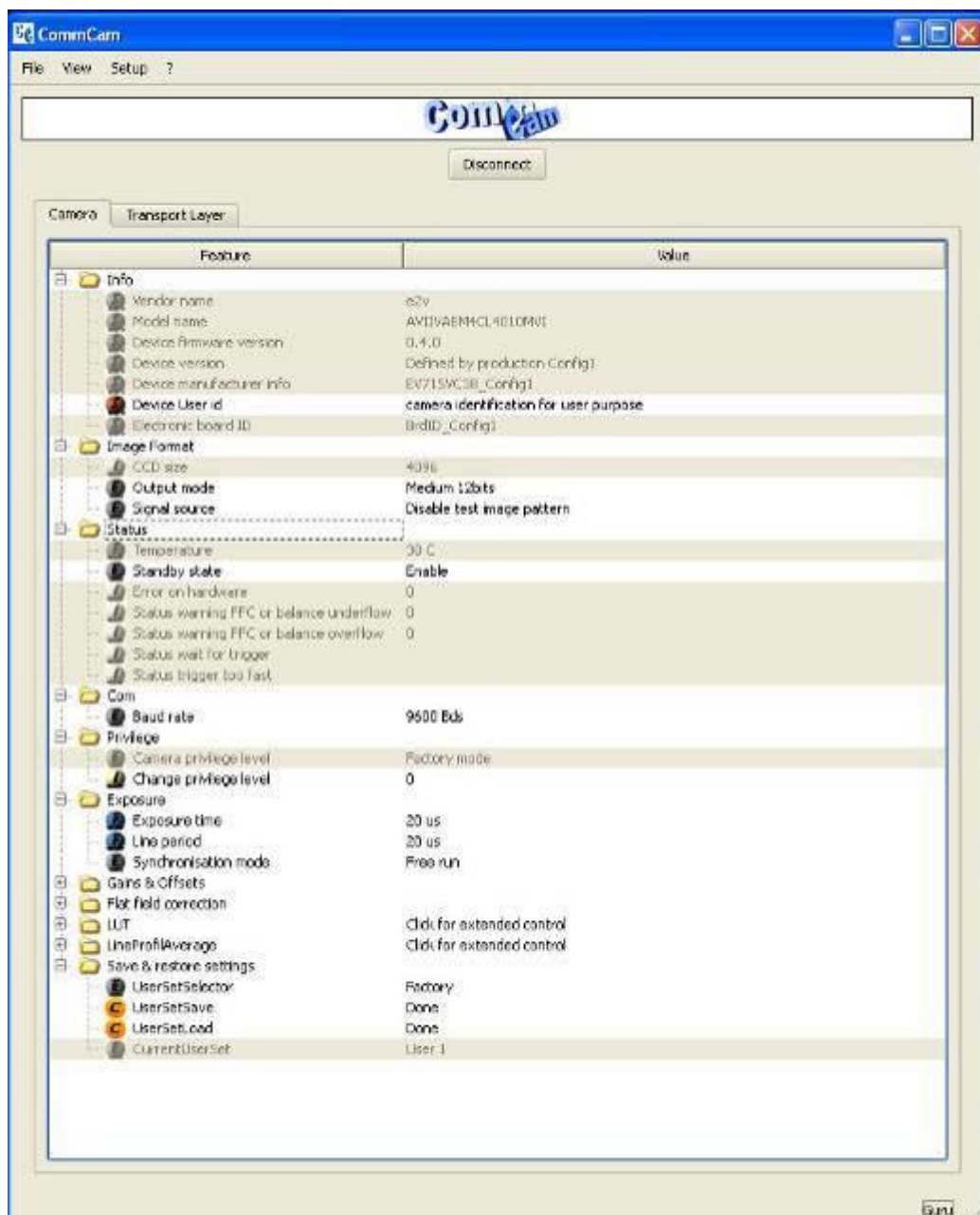

7.2 Serial Protocol and Command Format

The Camera Link interface provides two LVDS signal pairs for communication between the camera and the frame grabber. This is an asynchronous serial communication based on RS-232 protocol.

The serial line configuration is:

- Full duplex/without handshaking
- 9600 bauds (default), 8-bit data, no parity bit, 1 stop bit. The baud rate can be set up to 115200

7.2.1 Syntax

Internal camera configurations are activated by write or readout commands.

The command syntax for write operation is:

w <command_name> <command_parameters><CR>

The command syntax for readout operation is:

r <command_name><CR>

7.2.2 Command Processing

Each command received by the camera is processed:

- The setting is implemented (if valid)
- The camera returns ">"<return code><CR>

The camera return code has to be received before sending a new command.

Returned code	meaning
>0	(or ">OK") : All right, the command will be implemented
>16	Command Error (Command not recognize or doesn't exist)
>33	Invalid Access (the receipt of the last command has failed).
>34	Parameter out of range (the parameter of the last command send is out of range).
>35	Access Failure (bad communication between two internal devices).

7.2.3 GenICam ready

The CameraLink Standard is not yet compliant with GenICam Standard, but as much as possible, each command of the AVIIVA EM2/EM4 will have its correspondence with the Standard Feature Naming Convention of the GenICam Standard.

This correspondence is given in parenthesis for each feature/command as the following example :

- **Vendor name** (*DeviceVendorName*) : "e2v"



8 Camera Commands

8.1 Information

These values allow to identify the Camera. They can be accessed in CommCam software in the “Info” section



Info	
Vendor name	e2v
Model name	AVIIVAEM4CL4010MVI
Device firmware version	0.4.0
Device version	Defined by production Config1
Device manufacturer info	EV715VC38_Config1
Device User id	camera identification for user purpose
Electronic board ID	BrdID_Config1

All these values are fixed in factory and can't be changed (shaded) except the Camera User ID which can be fixed by the Customer :

- Vendor name (*DeviceVendorName*)** : “e2v”
 - ⇒ Read function : “r vdnm”;
 - Returned by the camera : “e2v”, string of 32 bytes (including “/0”)
 - ⇒ Can not be written
- Model Name (*DeviceModelName*)** : Internal name for GenICam :
 - ⇒ Read function : “r mdnm”;
 - Returned by the camera : String of 32 bytes (including “/0”) :
 - ⇒ Can not be written
- Firmware Version (*DeviceFirmwareVersion*)**: Get camera synthetic firmware version (PKG version)
 - ⇒ Read function : “r dfwv”;
 - Returned by the camera : String of 16 bytes (including “/0”)
 - ⇒ Can not be written
- Device Version (*DeviceVersion*)** : Get Camera Hardware version
 - ⇒ Read function : “r dhvv”;
 - Returned by the camera : String of 32 bytes (including “/0”)
 - ⇒ Can not be written
- Device Manufacturer Info (*DeviceManufacturerInfo*)** : Get Camera ID
 - ⇒ Read function : “r idnb”;
 - Returned by the camera : String of 128 bytes (including “/0”)
 - ⇒ Can not be written
- Electronic board ID (*ElectronicBoardID*)** : Get PcB Board ID
 - ⇒ Read function : “r bovd”;
 - Returned by the camera : String of 32 bytes (including “/0”)
 - ⇒ Can not be written
- Device User ID (*DeviceUserID*)** : Camera user identifier ID
 - ⇒ Read function : “r cust”;
 - Returned by the camera : String of 128 bytes (including “/0”)
 - ⇒ Write function : “w cust <idstr>”

8.2 Dump and Communication

- **Dump** : Allows to dump all the Camera info/settings in a text file. This command is available in the CommCam View Menu :

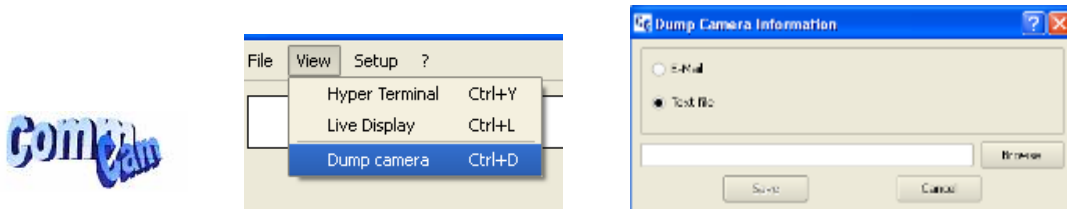

- **BaudRate (ComBaudRate)**: Set the Camera BaudRate. This command is available in the CommCam "Com" section :

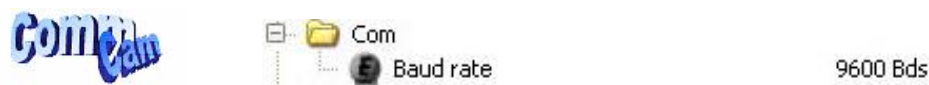

- ⇒ Read function : **"r baud"**;
Returned by the camera : Value of the Baud Rate
- ⇒ Write function : **"w baud" <index>** with the index as follows :
 - 1 : 9600 Bauds (default value at power up)
 - 2 : 19200Bds
 - 6 : 57600Bds
 - 12 : 115200Bds



After changing the communication rate, the communication with the Camera could be interrupted with the application (CommCam or whatever) it has made this change. The application has to reconnect with the appropriate baudrate. The baudrate will automatically switch to 9600 bds at the next power down/up.

8.3 Status, Temperature & Standby

It can be accessed in CommCam software in the “Status” section :

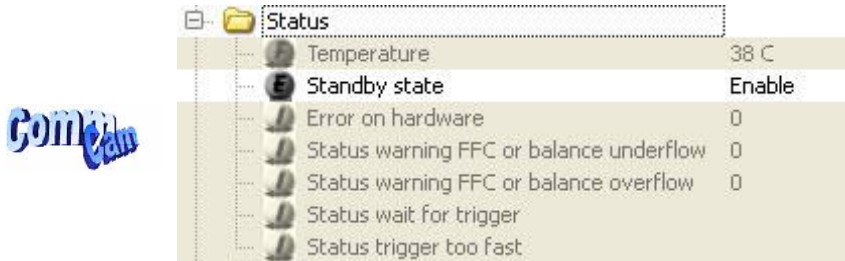

- **Temperature (*Temperature*)** : Get internal Temperature
 - ⇒ Read function : **“r temp”**;
 - Return by the camera : Temperature in Q10.2 format (8 bits signed + 2 bits below comma). Value is between -512 to 511 in °C.
 - The temperature Sensor is placed on the CCD driver Pcb Board, close to the Sensor itself.
 - The Temperature displayed is one of the highest possible in the Camera. Then it can be monitored to activate the standby mode, in case of too high temperature (see insert below)
 - The limits are always referenced by the internal temperature sensor. (cf **APPENDIX B : Thermal Management**)

- **Standby Mode (*Standby*)** : Activation of the Standby mode of the Camera
 - ⇒ Read function : **“r stby”**;
 - Returned by the camera : Boolean.
 - 0 : Disable Standby mode (False)
 - 1 : Enable standby mode (True)
 - ⇒ Write function : **“w stby <val>”**; <val> is 0 or 1.



A standby mode, what for ?

The Standby mode stops all activity on the sensor level. The power dissipation drops down to less than 4W. During the standby mode, the Camera carry on sending black images through the CameraLink outputs in order to avoid any disruption in the application system. Once the Standby mode turned off, the Camera recover in less than **1ms** to send images again from the sensor.

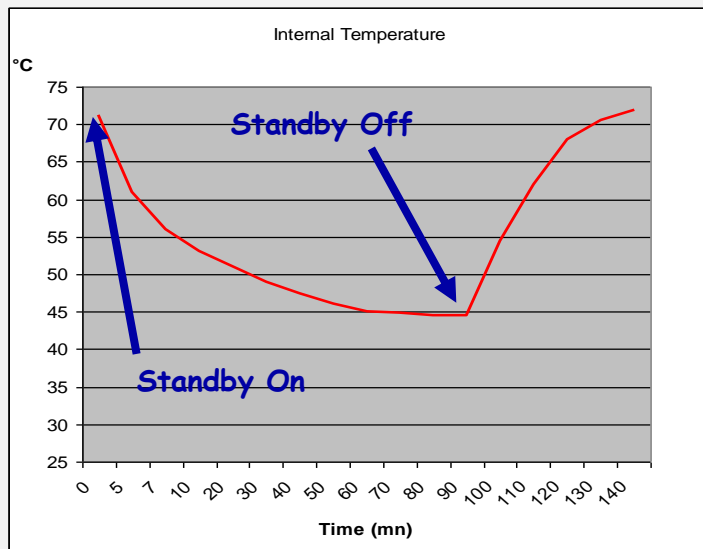

- **Camera status** : Get the Camera status register
 - ⇒ Read function : “**r stat**”;
 - Returned by the camera : 32bits integer :
 - Bit 0 : (*StatusWaitForTrigger*) : No trig received from more than 1sec
 - Bit 1 : (*StatusTriggerTooFast*) : Missing triggers. Trig signal too fast
 - Bits 2, 3, 4, 5, 6 and 7 : reserved.
 - Bit 8 : (*StatusWarningOverflow*) : True is an overflow occurs during FFC or Tap balance processing
 - Bit 9 : (*StatusWarningUnderflow*) : True is an underflow occurs during FFC or Tap balance processing
 - Bits 10, 11, 12, 13, 14, 15 : Reserved
 - Bit 16 : (*StatusErrorHardware*) : True if hardware error detected
 - Bits 17 to 31 : Reserved

8.4 Image Format

- **CCD Size** (*SensorWidth*) : Gives the number of pixel of the CCD. This value is available in the CommCam “Image Format” section :
 - ⇒ Read function : “**r ccdz**”;
 - Return by the camera : Integer 512 to 4096 depending on the sensor embedded in the Camera.
 - ⇒ Can not be written;
- **Signal source** (*TestImageSelector*) : Defines if the data comes from the Sensor or the FPGA (test Pattern). This command is available in the CommCam “Image Format” section :

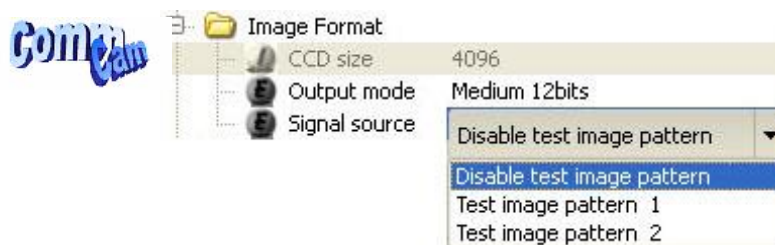

- ⇒ Read function : “**r srce**”;
- Returned by the camera : “0” if Source from the Sensor and “1” if test pattern active
- ⇒ Write function : “**w srce**” <value> :
 - “0” to switch to CCD sensor image
 - “1” to switch to Test Pattern 1 : **Detailed in APPENDIX A**
 - “2” to switch to Test Pattern 2 : **Detailed in APPENDIX A**

The test pattern is generated in the FPGA : It’s used to point out any interface problem with the Frame Grabber.

- **Output mode (*OutputMode*)** : Set the CameraLink Output mode (refer to Chap 3.2.3 : CameraLink Output Configuration). This command is available in the CommCam “Image Format” section :



- ⇒ Read function : “**r mode**”;
Returned by the camera : Output mode from 0 to 5 (see below). Values from 0 to 2 are reserved for EM4 only.
- ⇒ Write function : “**w mode**” <value> :
detailed in the table below :

Modes	Connector CL1	Connector CL2	Mode value
Base 40MHz (EM2) or 80MHz (EM4)			
2 Channels interlaced 8bits	2 x 40MHz or 80MHz 8 bits	-	3
2 Channels interlaced 10bits	2 x 40MHz or 80MHz 10 bits	-	4
2 Channels interlaced 12bits	2 x 40MHz or 80MHz 12 bits	-	5
Medium 40MHz (EM4 only)			
4 Channels x 40MHz 8bits	CameraLink Standard Medium mode in 4x40MHz		0
4 Channels x 40MHz 10bits	CameraLink Standard Medium mode in 4x40MHz		1
4 Channels x 40MHz 12bits	CameraLink Standard Medium mode in 4x40MHz		2

Structure of the Camera Link Channels for interfacing



■ **Camera EM2**

- **Base 40MHz** : 2 x Channels interlaced

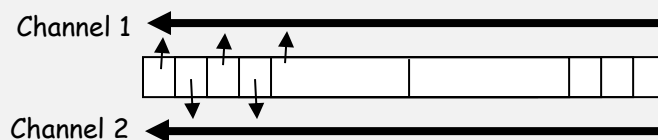

■ **Camera EM4**

- **Base 80MHz** : 2 x Channels separate diverge :

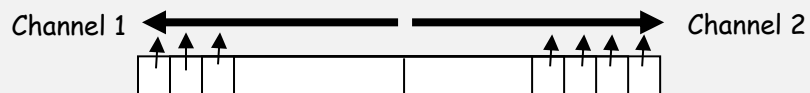

- **Medium 40MHz** : 4 x channels diverging, interlaced by 2

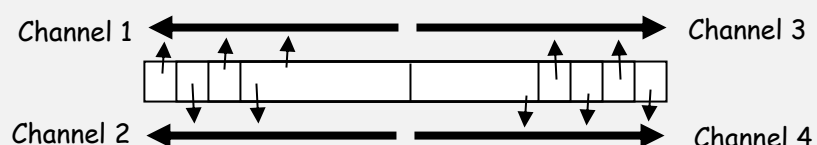

8.5 Exposure and Synchronization

- **Synchronisation Mode (SynchroMode)** : Timed or Triggered, it defines how the grabbing is synchronized. This command is available in the CommCam “Exposure” section :

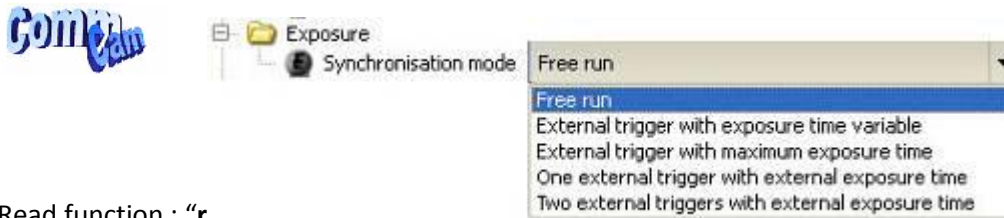

⇒ Read function : “r

Returned by the camera :

- 0 : Free Run mode
- 1 : Ext Trig with Integration time set in the Camera
- 2 : Ext Trig with Integration time maximum in the line period
- 3 : Ext ITC (Integration Time Controlled) : The same Trig signal defines the line period and its low level defines the integration time
- 4 : Ext Trig with two trig signal : CC2 defines the start of the integration and CC1 defines the Stop of the integration.

⇒ Write function : “w **sync**” <value>

8.5.1 Timing Specifications

- For all the modes detailed below, the **READOUT** is given as : $\text{NbPixels} / (\text{NbTaps} * 40\text{MHz})$

Readout Time	EM2	EM4	Unit
512 pixels	6,4	3,2	μsec
1024 pixels	12,8	6,4	μsec
2048 pixels	25,6	12,8	μsec
4096 pixels	51,2	25,6	μsec

- The necessary delay between the end of integration and the beginning of the readout (tdr) is calculated as 53 pixels at 40MHz : **tdr = 1,325μs**
- In the following timing diagrams, the line Period min is defined as : **LPmin = Readout + tdr**

Free Run

This mode doesn't require an external trigger.

In this case, the line period (t_{per}) can be defined in the Camera (see below) but the real line period of the camera depends also on the exposure time (t_{int}) set :

- If $t_{int} > t_{per}$, the line period is equal to t_{int}

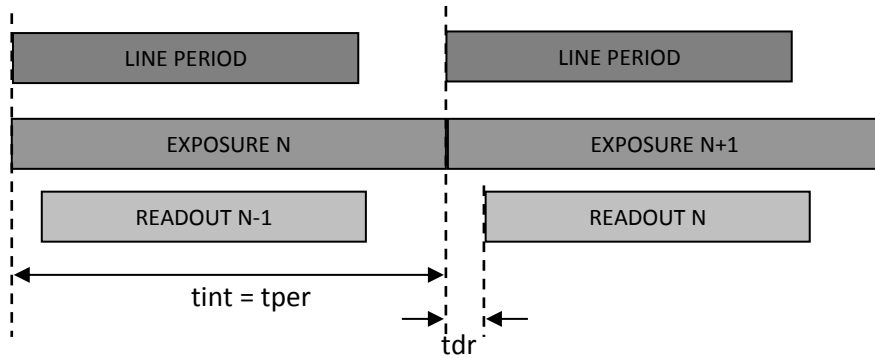

- If $t_{per} > t_{int}$, the line period is equal to t_{int}

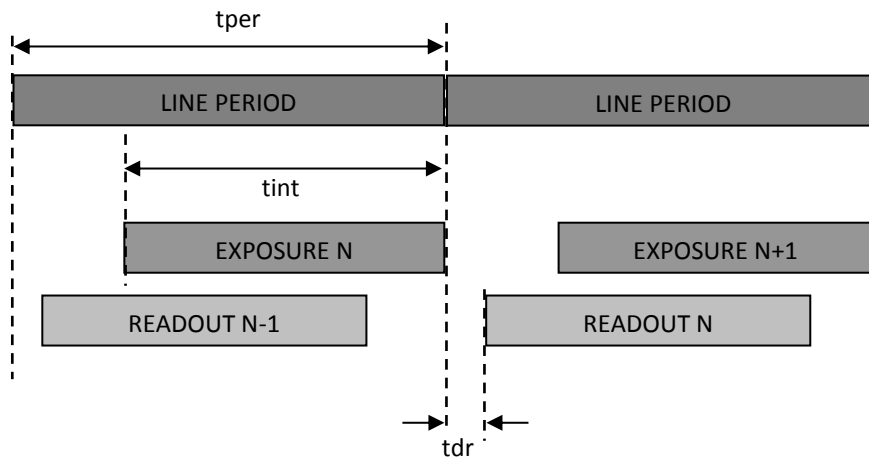

Label	Min	Typical	Max	Unit
tint	1	-	6553,5	μsec
tper	LPmin	-	6553,5	μsec
tdr	-	1,32	-	μsec

Ext Trig with Exposure time set in the camera

This mode requires an external trigger (via CC1) but the exposure time is the one defined in the Camera.



If the line period of the Trig signal provided to the camera is lower than the exposure time set in the camera, the “short trig pulses” will be ignored : The exposure set in the camera defines the minimum line period possible.

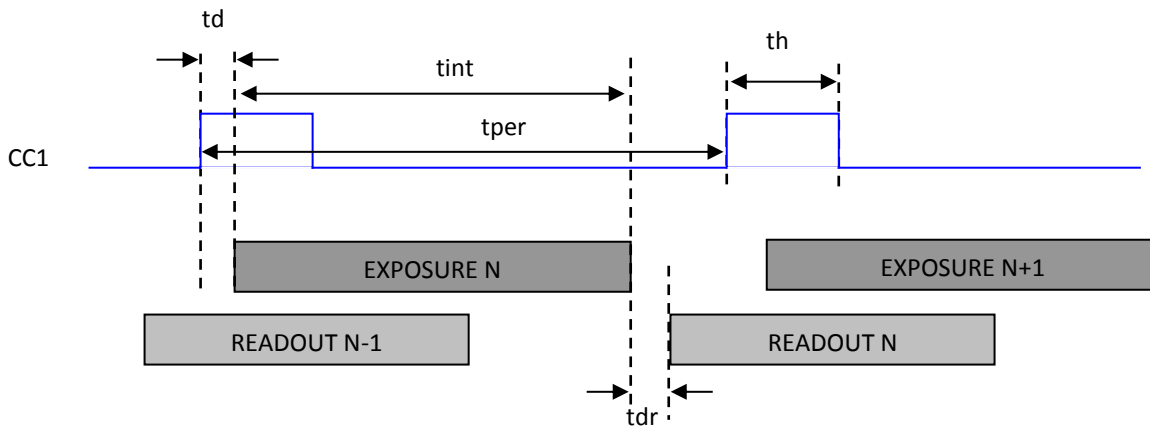

The Minimum Line period taken in account by the Camera is the maximum between :

MinLP = Exposure time + td + tdr. And LPmin

Label	Min	Typical	Max	Unit
tint	1			µsec
tper	MinLP	-	-	µsec
th	0,3	-	-	µsec
td	-	0,25	-	µsec
tdr	-	1,32	-	µsec

Ext Trig Full Exposure time available

This mode requires an external trigger (via CC1). The exposure time is the maximum possible value between two Tri pulses.

In this mode, the exposure time set in the camera is ignored.



Avoid this mode if your trigger is not stable (variable line period) : The exposure of each line could then be different. If the period of the trig signal is less than the readout time, the Camera won't send any signal.

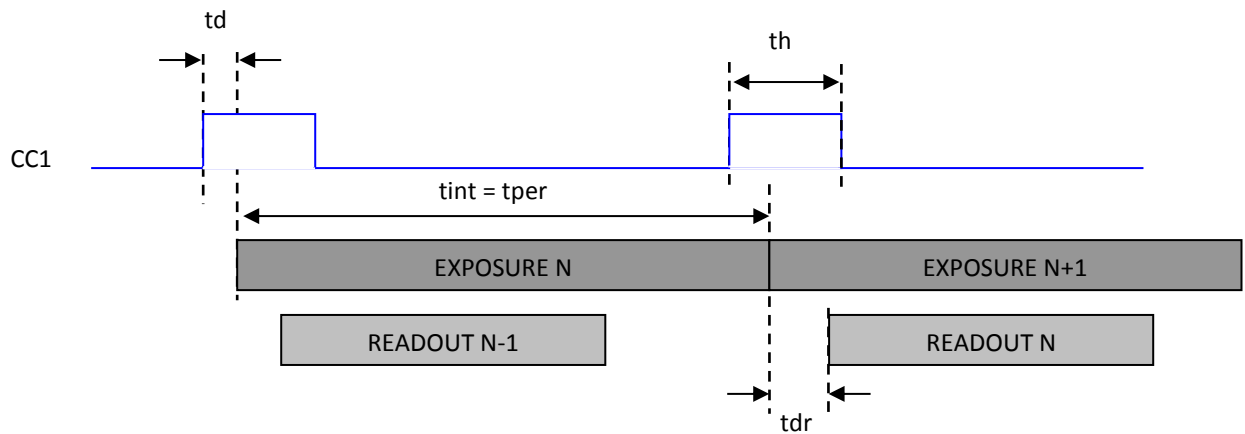

Label	Min	Typical	Max	Unit
tper/tper	LPmin	-	-	μsec
th	0,3	-	-	μsec
td	-	0,95	-	μsec
tdr	-	1,32	-	μsec

Ext Trig with Exposure Time Controlled (ITC) with one Trig

This mode requires an external trigger (via CC1). Both exposure time and line period are defined by this Trig signal :

- The exposure time during the low level of the Trig Signal
- The line period between two rising edges of the Trig Signal

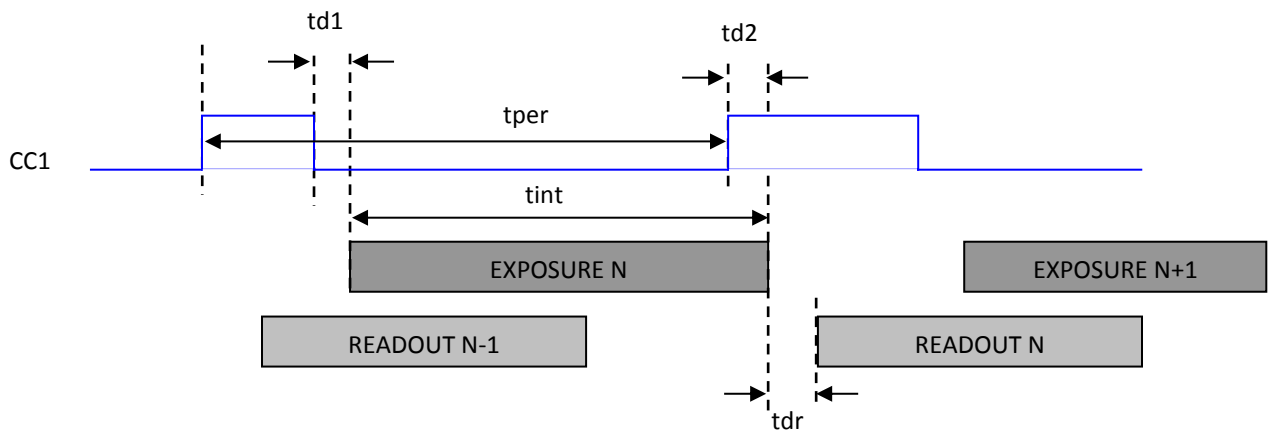

Label	Min	Typical	Max	Unit
tint	1	-	-	μsec
tper	LPmin	-	-	μsec
td1	-	0,1	-	μsec
td2	-	0,95	-	μsec
tdr	-	1,32	-	μsec

Ext Trig with Integration Time Controlled (ITC) with two Trigs

This mode requires two external triggers (via CC1 and CC2) :

- CC2 controls the starting of the exposure time
- CC1 controls the end of the exposure time.

The line period is defined by the one of the CC2 Trig signal.

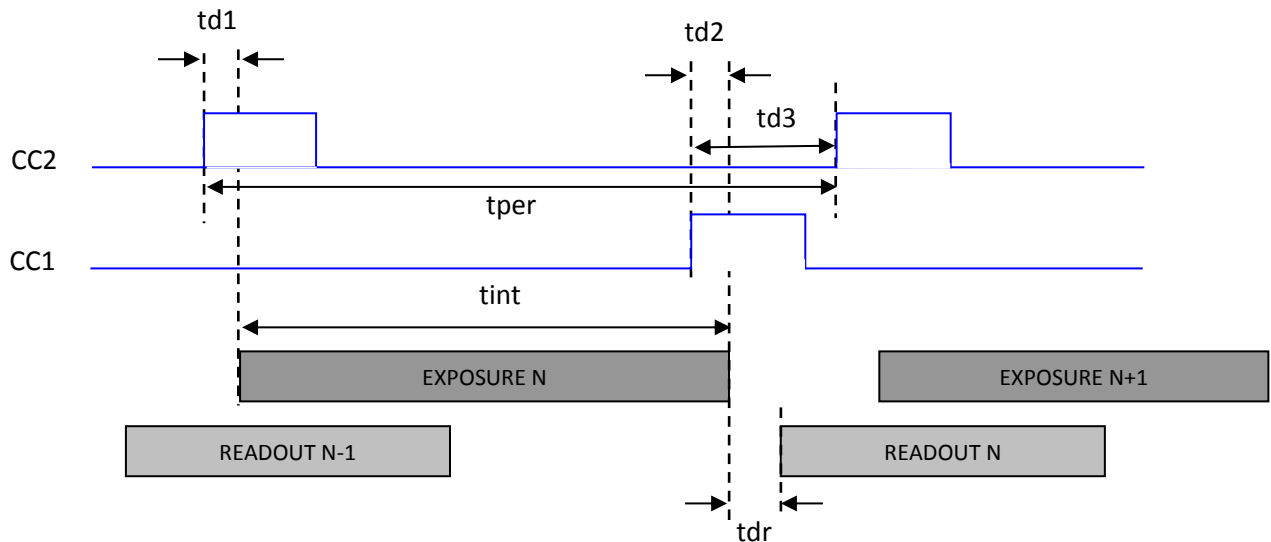

Label	Min	Typical	Max	Unit
tint	1			μ sec
tper	LPmin	-	-	μ sec
td1	-	0,1	-	μ sec
td2	-	0,95	-	μ sec
td3	0,1			
tdr	-	1,32	-	μ sec

- **Exposure time (*ExposureTimeAbs*):** Defines the exposure time when set in the Camera. This command is available in the CommCam “Exposure” section :

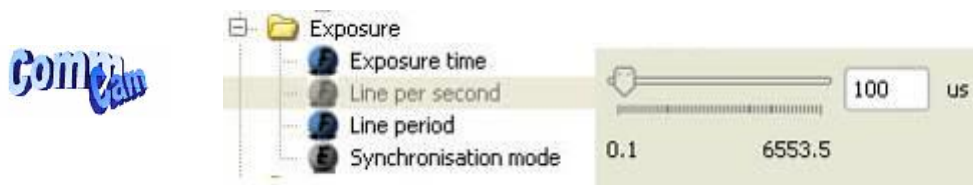

- ⇒ Read function : “**r tint**”;
- Returned by the camera : Integer from 10 to 65535 (=1 μ s to 6553,5 μ s by step o 100ns)
- ⇒ Write function : “**w tint**” <value> ;

This value of exposure time is taken in account only when the synchronisation mode is “free run” (0) or “Ext Trig with Exposure time set” (1). Otherwise it’s ignored.

- **The real effective minimum exposure time value is 1 μ s.**

- **Line Period (*LinePeriod*)** : Defines the Line Period of the Camera in Timed mode. This command is available in the CommCam “Exposure” section :

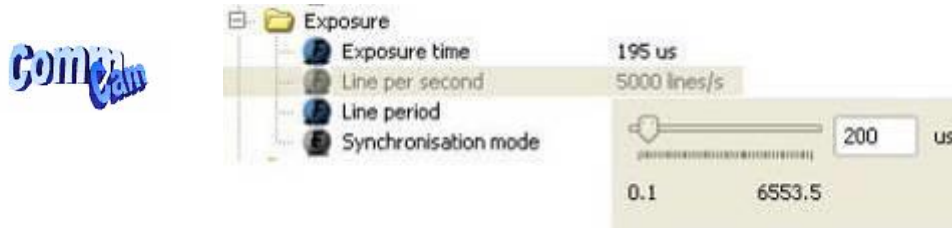

- ⇒ Read function : “**r tper**”;
Returned by the camera : Integer from 1 to 65536 (=0,1µs to 6553,6µs by step o 100ns)
- ⇒ Write function : “**w tper**” <value> ;

The line period is active only in Free Run mode. It’s also disabled if in this mode, the Integration time is set higher than the Line Period.

The Line frequency indication (line per second) is calculated as : 1/Line Period.

- **The real effective minimum Line Period value accepted by the camera is indicated below.**



the Line period can’t be set under a certain minimum value otherwise, it will be ignored by the camera which will return an error code. This minimum value is defined as follows :

	512 pixels	1k pixels	2k pixels	4k pixels
For EM2 :	7.72µs	14,12µs	26.92µs	52,52µs
For EM4 :	4,52µs	7.72µs	14,12µs	26.92µs

*Note that these values are equivalent to : **LPmin = Readout + tdr** (1,32µs)*

8.6 Gain and Offset



Ultimate Concept: A different way to set the Gain in order to improve the Tap balance

The “U” Concept has been developed to get a real improvement in term of tuning for the multi-Tap sensors :

As each sensor tap is driven by a different analog Chain, for an increasing of the global gain of the Camera, each tap can have a different behavior on its own Gain and offset.

This means that to be perfectly adjusted, a balance of the taps should be performed ideally after each change of the Gain. The Ultimate Concept offers a solution as following:

The Global analog Gain of the Camera is divided in 2 parts :

A preamp-Gain which is composed of several steps (5 x steps of 6dB, from -24dB to 0dB on the AVIIVA EM2/EM4)

An amplification Gain with a continuous tuning (from 0dB to +8dB on the AVIIVA EM2/EM4)

At each step of Preamp Gain, a Tap balance has been performed in factory for both Gains and Offsets and saved in ROM memory. When a new value of Preamp Gain is set, the factory settings of the both Gain and offset balance is automatically reloaded.

For sure, the user can also perform his own balance (automatically or manually) and can save it in one of the four dedicated memory banks.

After the Preamp Gain level, the user can add more gain by using the Amplification Gain:

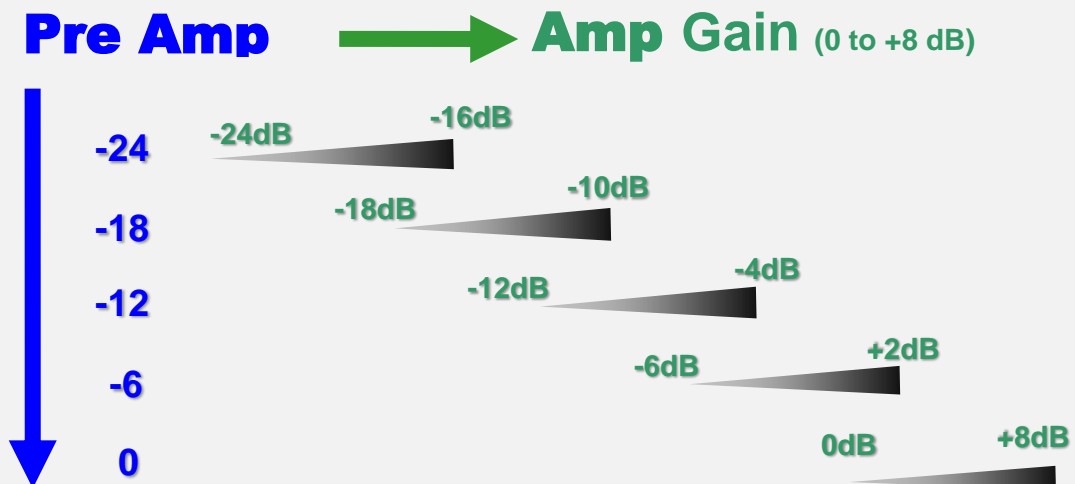

The best tuning is when the Amplification Gain is set at its minimum possible

Each change of Preamp Gain value loads automatically the associated values of the Tap balance (Gain and offset for each sensor tap).

The Global Chain of Gain is described as following :

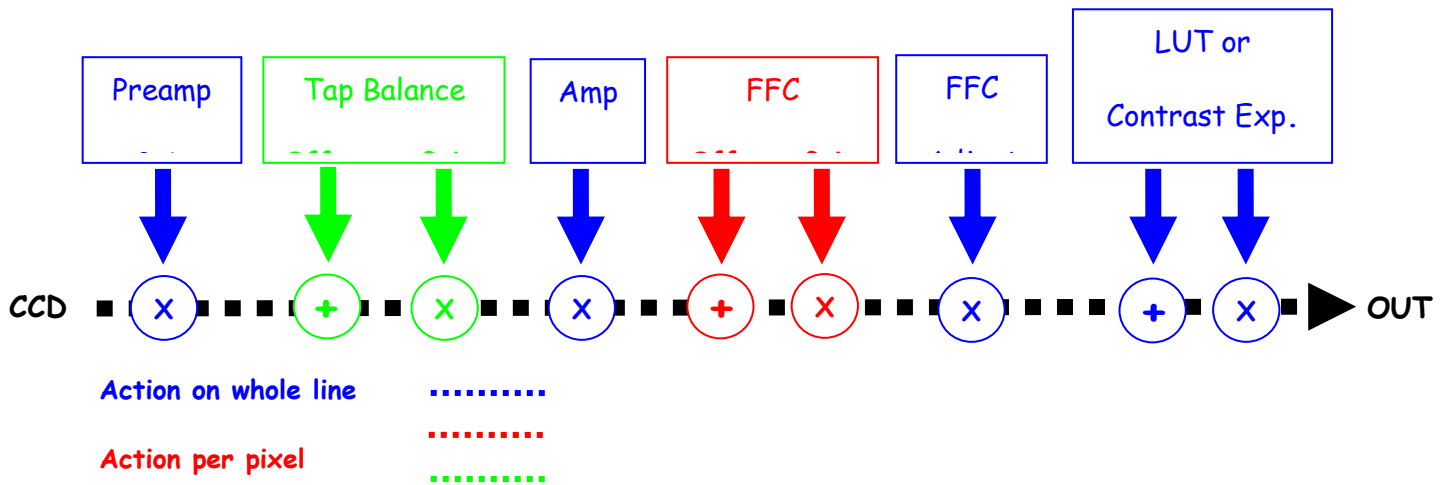

8.6.1 Analog Gain

- **Preamp Gain** : (*GainAbs* with *GainSelector= AnalogAll*)
Set the Pre-amplification Gain. This command is available in the CommCam “Gain & Offset” section. The Preamp Gain is set by step of 6dB :



- ⇒ Read function : “**r pamp**”;
Returned by the camera : Integer corresponding to one of the 5 different step values :
 - 0 : (-24dB)
 - 1 : (-18dB)
 - 2 : (-12dB)
 - 3 : (-6dB)
 - 4 : (0dB)
- ⇒ Write function : “**w pamp**” <int> ;

- **Gain**: (*GainAbs* with *GainSelector= GainAll*)
Set the Amplification Gain. This command is available in the CommCam “Gain & Offset” section :



- ⇒ Read function : “**r gain**”;
Returned by the camera : Value from 0 to 6193 corresponding to a Gain range of 0dB to +8dB calculated as following : $Gain(dB) = 20 \cdot \log(1 + Gain/4096)$.
- ⇒ Write function : “**w gain**” <int> ;

8.6.2 Tap Balance



How to perform a Tap Balance ?

Why and when performing a Tap Balance ?

Each output of the sensor (Tap) has its own analog Chain and behavior. There could have some discrepancies between these outputs in extreme conditions of Gain or temperature
The Tap balance is already performed in factory for each level of Preamp-Gain. If necessary, the Tap balance can be performed again by the User on both Offsets and Gains

The Procedure is the following :

Tap Balance by Offsets

- Cover the Lens of the camera to get a dark uniform target. This is not recommended to perform an Offset balance under light conditions.
- Launch the Tap Offset Balance
- The process takes a few seconds and can be interrupted when you want

Tap Balance by Gains

- Provide an uniform light target to the camera : This is recommended to have a global level of around at least 70% of the saturation, otherwise, with a low light level (< 30% of the Saturation) the Gain has less effect than the Offset and your balancing won't be efficient.
- Launch the Tap Gain Balance
- The process takes a few seconds and can be interrupted when you want
- You can save the result in memory (result for both Gains and offsets).

Internal Process

During the calibration process, the Camera calculates averages on some strategic ROIs (around the junction between taps) and then estimates the slope of the tangents and then the projections on each side of the junction.

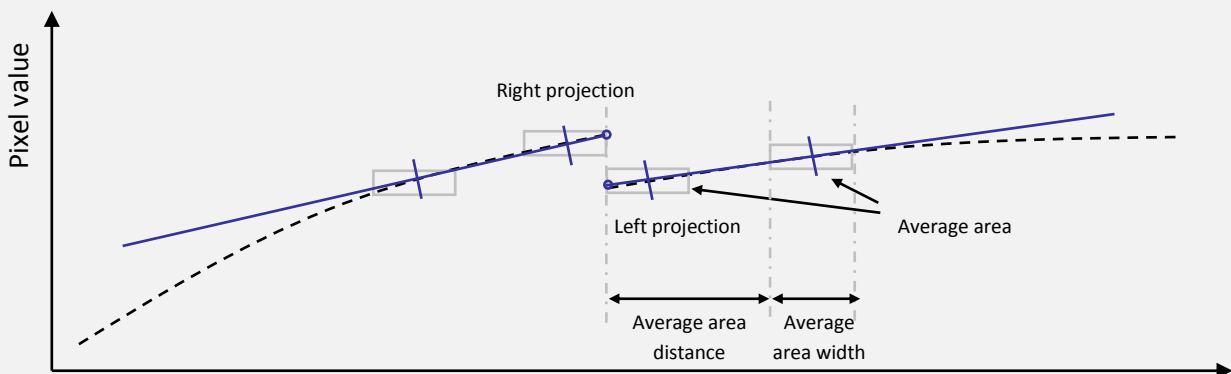

The adjustment between these two neighbor taps is calculated to cancel the difference between the two projections (right and left).

- **Automatic Gain & Offset Tap balance:** All the commands are available in the CommCam “Gain & Offset / Automatic Balance” section :



- **Offsets Balance (*BlackLevelAutoBalance*) :**
 - ⇒ Read function : “**r balo**”;
Returns the Offset Balance status : 1 for running and 0 for stopped.
 - ⇒ Write function :
 - “**w balo 1**” : Starts the offset balance. The value switches back to 0 automatically when the balance process is finished (“Offset Balance control” in CommCam)
 - “**w balo 0**” : Stops the offset balance. No action if the process is already finished (“Abort Offset balance Control” in CommCam).
- **Gains Balance (*GainAutoBalance*):**
 - ⇒ Read function : “**r balg**”;
Returns the Tap Balance status : 0 if finished.
 - ⇒ Write function :
 - “**w balg 1**” : Starts the offset balance.
The value switches back to 0 automatically when the balance process is finished (“Gain Balance control” in CommCam)
 - “**w balg 0**” : Stops the Gain balance. No action is the process is already finished (“Abort Gain balance Control” in CommCam).

- **Manual Gain & Offset Tap balance:** All the commands are available in the CommCam “Gain & Offset / Automatic Balance” section :

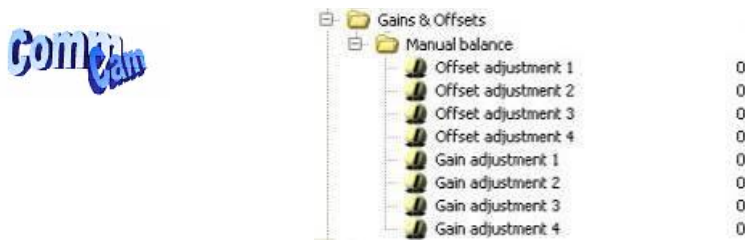

- **Tap Offset (*BlackLevelRaw* with *BlackLevelSelector=Tapx*)**
 - ⇒ Read function : “**r off<tap>**”; <tap> is 1 to 4 (EM4) or 1 to 2 (EM2)
Returns the Offset value for the tap. Ex : “*r off1*” returns offset value Tap1.
 - ⇒ Write function : “**w off<tap> <value>**”
 - <tap> is 1 to 4 (EM4) or 1 to 2 (EM2)
 - <value> : from -4096 to +4095 by step of 1 (gray levels)
- **Tap Gain (*GainAbs* with *GainSelector=Tapx*) :**
 - ⇒ Read function : “**r fga<tap>**”; <tap> is 1 to 4 (EM4) or 1 to 2 (EM2)
Returns the Gain value for the tap. Ex : “*r fga1*” returns Gain value Tap1.
 - ⇒ Write function : “**w fga<tap> <value>**”
 - <tap> : 1 to 4 (EM4) or 1 to 2 (EM2)
 - <value> : from -128 to +127 by step of 1 (0,0021dB each step)

8.6.3 Contrast Expansion

- **Digital Gain** (*GainAbs* with *GainSelector=DigitalAll*) : Set the global Digital Gain. This command is available in the CommCam “Gain & Offset” section :



- ⇒ Read function : “**r gdig**”;
Returned by the camera : Integer value from 0 to 255. The corresponding Gain is calculated as $20\log(1+val/64)$ in dB
- ⇒ Write function : “**w gdig**” <int> ;

- **Digital Offset** (*BlackLevelRaw* with *BlackLevelSelector=All*) : Set the global Digital Offset. This command is available in the CommCam “Gain & Offset” section :



- ⇒ Read function : “**r offs**”;
Returned by the camera : Value from –4096 to +4095 in LSB
- ⇒ Write function : “**w offs**” <int> ;



The Contrast Expansion (both Digital Gain & Offset) will be automatically disabled if the LUT is enabled..

8.7 Flat Field Correction



How is performed the Flat Field Correction ?

What is the Flat Field correction (FFC) ?

The Flat Field Correction is a digital correction on each pixel which allows :

- To correct the Pixel PRNU (Pixel Response Non Uniformity) and DSNU (Dark Signal Non Uniformity)
- To Correct the shading due to the lens
- To correct the Light source non uniformity

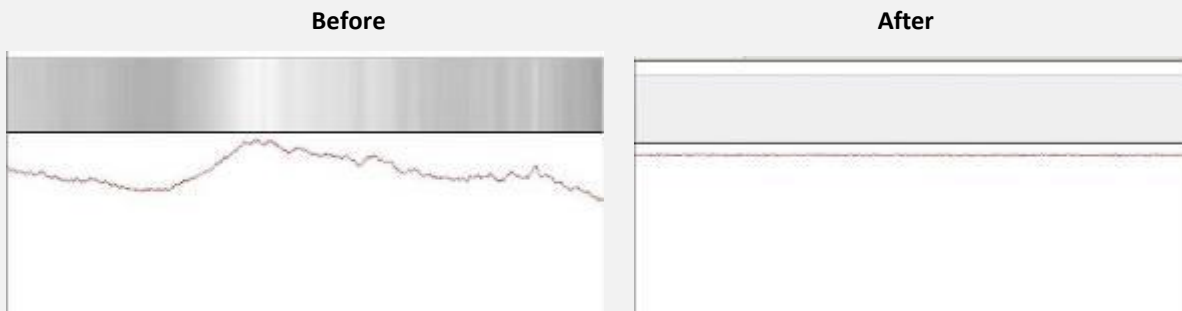

How is calculated / Applied the FFC ?

The FFC is a digital correction on the pixel level for both Gain and Offset.

➤ Each Pixel is corrected with :

- An Offset on 8 bits (Signed Int 5.3). They cover a dynamic of $\pm 16\text{LSB}$ in 12bits with a resolution of $1/8\text{ LSB}$ 12bits.
- A Gain on 14 bits (Unsigned Int 14) with a max gain value of x3
- The calculation of the new pixel value is : $P' = (P + \text{Off}).(1 + \text{Gain}/8192)$

The FFC processing can be completed with an automatic adjustment to a global target. This function is designed as “**FFC Adjust**”. This adjustment to a User target is done by an internal hidden gain which is re-calculated each time the FFC is processed while the FFC adjust function is enabled.

The FFC is always processed with the max pixel value of the line as reference. If enabled, the FFC adjust module (located at the output of the FFC module) calculates the adjustment gain to reach the target defined by the User.

When the FFC result is saved in memory, the adjust gain and target are saved in the same time in order to associate this gain value with the FFC result.

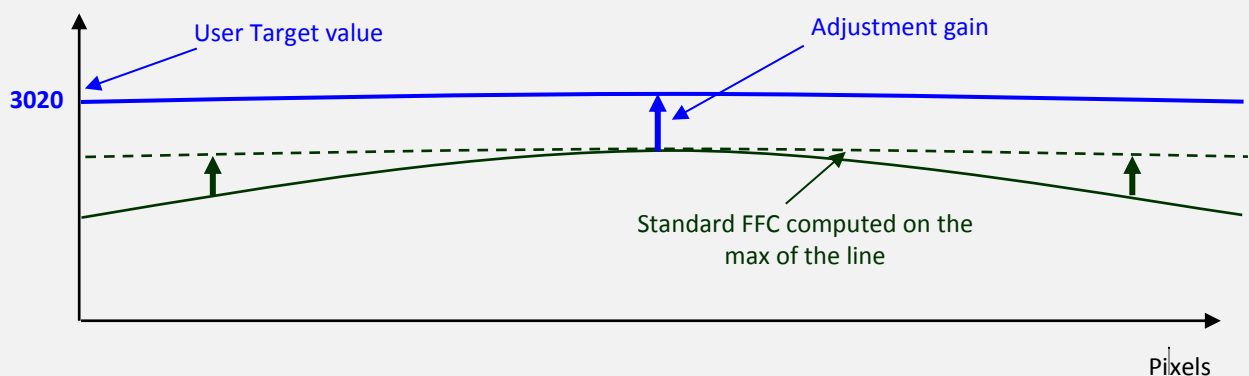

How to perform the Flat Field Correction ?

FPN/DSNU Calibration

- Cover the lens
- Launch the FPN Calibration : Grab and calculation is performed in few seconds

PRNU Calibration

The User must propose a white/gray uniform target to the Camera (not a fixed paper).
 The Gain/Light conditions must give a non saturated image in any Line.
 The Camera must be set in the final conditions of Light/ Gain and in the final position in the System.
 If required, set a user target for the FFC adjust and enable it.

- White uniform (moving) target
- Launch the FFC
- Enable the FFC
- You can save the FFC result (both FPN+PRNU in the same time) in one of the 4 x FFC User Banks.
- The user target and Gain are saved with the associated FFC in the same memory.

Advices

The AVIIVA EM2/EM4 Cameras have 4 x FFC Banks to save 4 x different FFC calibrations. You can use this feature if your system needs some different conditions of lightning and/or Gain because of the inspection of different objects : You can perform one FFC per condition of Gain/setting of the Camera (4 Max) and recall one of the four global settings (Camera Configuration + FFC + Line Balance) when required.

8.7.1 Activation, Filter and Auto-Adjust

- **FFC Activation (*FFCEnable*)** : Enable/disable the Flat Field Correction. This command is available in the CommCam “Flat Field Correction” section :

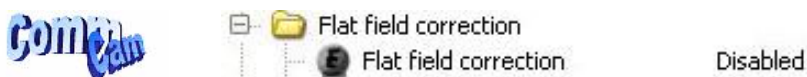

- ⇒ Read function : “**r ffc**” : Returns the FFC Status (0 if disabled, 1 if enabled)
- ⇒ Write function :
 - “**w ffc 1**” : Enable the FFC.
 - “**w ffc 0**” : Disabled the FFC

- **FFC Low band Filter (*FFCFilter*)** : Control the FFC Low Band Filter. This command is available in the CommCam “Flat Field Correction/ Automatic Calibration” section :

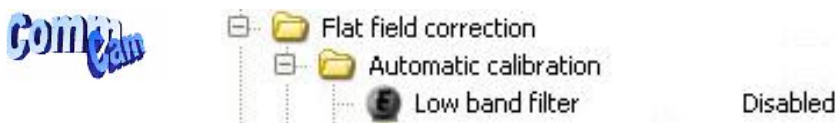

- ⇒ Read function : “**r ffc**” : Returns the Filter Status (0 if disabled)
- ⇒ Write function :
 - “**w ffc 0**” : Disable the Low Band Filter

- “w ffcf 1” : Set the filter to “1 neighbour pixel”
- “w ffcf 2” : Set the filter to “2 neighbour pixels”
- “w ffcf 3” : Set the filter to “3 neighbour pixels”



What is the use of the Low Band Filter ?

The basic idea of this filter is to get a uniform white target before processing the Flat Field correction (PRNU coefficients) even by using only a white non-moving paper as target for the scene. This filter can also be distinguished from the Flat Field Correction and used as an “online pixel correction”, at least when its value is set to 1 (neighbor pixel).

Whatever the level of filter used, it will correct only “high band” noise and have a poor effect on low band non uniformity noise : Then the result of any pre-filtering of the white target before FFC will depends on the magnification used in the system. And the “size” of the non-uniformities to be corrected.

- **FFC Adjust Function** : This Feature is available in the CommCam “Flat Field Correction/ Automatic Calibration” section :



- **Gains adjust (FFCAdjust)**: Enable/Disable the function
 - ⇒ Read function : “r ffad”. Returns the status of the function (0 if disabled)
 - ⇒ Write function :
 - “w ffad 0” : Disable the FFC Adjust function.
 - “w ffad 1” : Enable the FFC Adjust function.
- **Auto Adjust Target Level (FFCAutoTargetLevel)**: set the value for the User Target.
 - ⇒ Read function : “r tfad”. Returns the Target value (from 0 to 4095)
 - ⇒ Write function : “w tfad <value>” : Set the Target Value (in 12bits)



FFC Adjust : A good usage.

When there are several Cameras to set up in a system on a single line, the most difficult is to have a uniform lightning whole along the line.

If each Camera performs its own Flat field correction, relative to the max of each pixel line, the result will be a succession of Camera lines at different levels.

=> The FFC Adjust function allows to set the same target value for all the Cameras in the system and then to get a perfect uniform line whole along the system with a precision of 1 LSB to the Target.

The reasonable value for the User Target is not more than around 20% of the max value of the line.

8.7.2 Automatic Calibration

FPN/DSNU Calibration :

- **FPN Calibration Control (*FPNCalibrationCtrl*)** : Launch or abort of the FPN process for the Offsets calculation. These commands are available in the CommCam “Flat Field Correction / Automatic Calibration ” section :

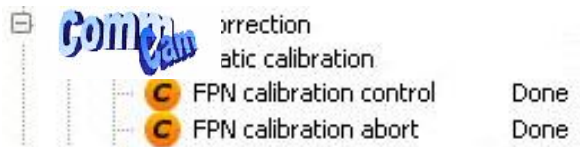

- ⇒ Read function : “**r calo**” : Returns the FPN Calculation Process Status (0 if finished, 1 if processing)
- ⇒ Write function :
 - “**w calo 1**” : Launch the FPN Calibration Process.
 - “**w calo 0**” : Abort the FPN Calibration Process.
- **FPN Coefficient Reset (*FPNReset*)** : Reset the FPN (Offsets) coefficient in Memory. This command is available in the CommCam “Flat Field Correction / Manual Calibration ” section :

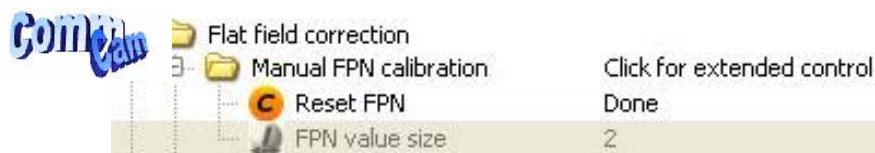

- ⇒ Write function : “**w rsto 0**” : Reset (set to 0) the FPN coefficients in memory. This doesn’t affect the FFC User Memory Bank but only the active coefficients in Memory.

PRNU Calibration :

- **PRNU Calibration Control (*FFCCalibrationCtrl*)** : Launch or abort of the PRNU process for the Gains calculation. This command is available in the CommCam “Flat Field Correction / Automatic Calibration ” section :



- ⇒ Read function : “**r calg**” : Returns the PRNU Calculation Process Status (0 if finished, 1 if processing)
- ⇒ Write function :
 - “**w calg 1**” : Launch the PRNU Calibration Process.
 - “**w calg 0**” : Abort the PRNU Calibration Process.
- **PRNU coefficient Reset (*PRNUReset*)** : Reset the PRNU (Gains) coefficient in Memory. This command is available in the CommCam “Flat Field Correction / Manual Calibration ” section :

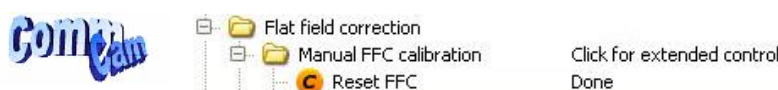

- ⇒ Write function : “**w rstg 0**” : Reset (set to 0) the FPN coefficients in memory. This doesn’t affect the FFC User Memory Bank but only the active coefficients in Memory.



Some Warnings can be issued from the PRNU/FPN Calibration Process as “pixel Overflow” of “Pixel Underflow” because some pixels have been detected as too high or too low in the source image to be corrected efficiently.

The Calculation result will be proposed anyway as it’s just a warning message.

The Status Register is the changed and displayed in CommCam “Status” section :

Status	
Status warning FFC or balance underflow	0
Status warning FFC or balance overflow	0

8.7.3 Manual Flat Field Correction

The FFC Coefficients can also be processed outside of the Camera or changed manually by accessing directly their values in the Camera : This is the “Manual” FFC.

In CommCam, the User can access to a specific interface by clicking on “click for extended control” in both “Manual FFC calibration” and “Manual FPN calibration sections” :



This will allow the user to upload/download out/in the Camera the FFC coefficients in/from a binary or text file that can be processed externally.

- FPN coefficients modification** : Direct access to the FPN coefficients for reading or writing. The FPN coefficients are read packets of x128 coefficients :
 - ⇒ Read function : “**r ffco <addr>**” : Read 128 consecutive FPN user coefficients starting from **<addr>** address. Returned value is in hexadecimal, without space between values (one unsigned short per coefficient).
 - ⇒ Write function : “**w ffco <addr><val>**” : Write 128 consecutive FPN user coefficients starting from the **<addr>** address. **<val>** is the concatenation of individual FPN values, without space between the values (one unsigned short per coefficient).

- **PRNU coefficients modification** : Direct access to the PRNU coefficients for reading or writing. The PRNU coefficients are read packets of x128 coefficients :
 - ⇒ Read function : “**r ffcg <addr>**” : Read 128 consecutive PRNU user coefficients starting from **<addr>** address. Returned value is in hexadecimal, without space between values (one unsigned short per coefficient).
 - ⇒ Write function : “**w ffcg <addr><val>**” : Write 128 consecutive PRNU user coefficients starting from the **<addr>** address. **<val>** is the concatenation of individual PRNU values, without space between the values (one unsigned short per coefficient).

8.7.4 FFC User Bank Management

The new-processed FFC values can be saved or restored in/from 4 x User banks.

Both Gains and Offsets in the same time but also the FFC Adjust User target and associated gain.

These functions are available in the Flat Field correction/Save & Restore FFC section :



- **Restore FFC from Bank (*RestoreFFCFromBank*)** : Restore the FFC from a Bank in the current FFC.
 - ⇒ Read function : “**r rffc**” : Get the current FFC Bank used
Returned by the camera : 0 for Factory bank or 1 to 4 for User banks
 - ⇒ Write function : “**w rffc <val>**” : Bank **<val>** 1 to 4 for User banks

Note : Factory means neutral FFC (no correction).
- **Save FFC in User Bank (*SaveFFCToBank*)** : Save current FFC in User Bank
 - ⇒ Can not de read
 - ⇒ Write function : “**w sffc <val>**” : User bank **<val>** if from 1 to 4.

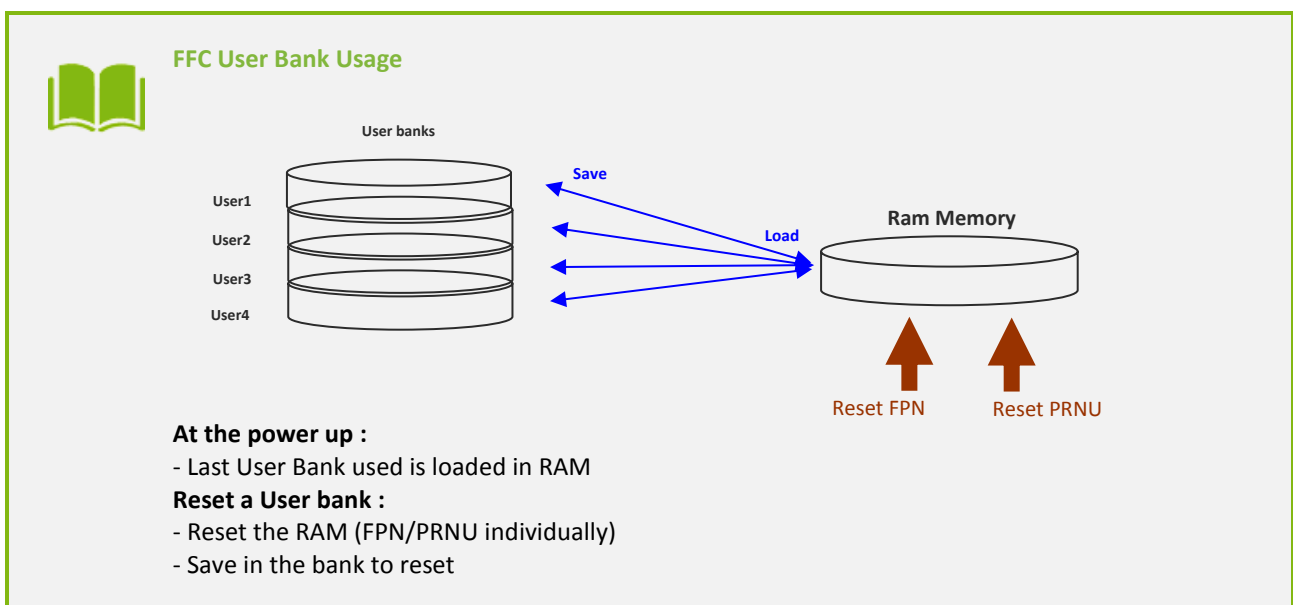

8.8 Look Up Table

The User can define an upload a LUT in the Camera that can be used at the end of the processing.

The LUT is defined as a correspondence between each of the 4096 gray levels (in 12 bits) with another outputted value. For example, a “negative” or “reverse” LUT is the following equivalence :

Real value	Output value
0	4095
1	4094
2	4093
...	...

Then the size of each value is 12bits but the exchanges with the Application/PC are done on 16 bits :

For 4096 gray levels (from 0 to 4095) the total file size for a LUT is 8Ko.

If this LUT is enables, the “Contrast Expansion” feature (digital Gain and Offset) will be disabled

- **LUT Enable (*LUTEnable*)** : Enable the LUT and sizable the Digital Gain / Offset
This function is available in the LUT section .:



- ⇒ Read function : “**r lute**” : Get the LUT status
Returned by the camera : 0 is LUT disabled, 1 if enabled
- ⇒ Write function : “**w lute <val>**” : <val> is 0 for disable, 1 for enable

- **Upload / Download the LUT coefficients** : Direct access to the LUT coefficients for reading or writing. In CommCam, the User can access to a specific interface by clicking on “click for extended control” in the LUT section :



- ⇒ Read function : “**r lutc <addr>**” : Read 128 LUT coefficients starting from address <addr> from 0 to 4095-128. Returned value is the concatenation in hexadecimal of individual LUT values, without space between values. (one unsigned short per coefficient)
- ⇒ Write function :” **w lutc <addr><val>** : Write 128 LUT coefficients starting from address <addr> form 0 to 4095-128. <val> is the concatenation in hexadecimal of individual LUT values, without space between values. (one unsigned short per coefficient)

- **Save & Restore LUT in User Banks** : The LUT loaded in RAM memory can be saved or restored in/from 4 User banks.

These functions are available in the LUT/Save & Restore LUT Settings section :



- **Restore LUT from Bank (*RestoreLUTFromBank*)** : Restore the LUT from a User Bank in the current RAM Memory.
 - ⇒ Read function : **"r rlut"** : Get the current LUT Bank used
Returned by the camera : 1 to 4 for User banks
 - ⇒ Write function : **"w rlut <val>"** : Bank <val> 1 to 4 for User banks
- **Save LUT in User Bank (*SaveLUTToBank*)** : Save current LUT in User Bank
 - ⇒ Can not de read
 - ⇒ Write function : **"w slut <val>"** : User bank <val> if from 1 to 4.

The bank number <val> is given in (*LUTSetSelector*)

8.9 Statistics and Line Profile

This function allows the User to get some statistics on a pre-defined ROI. On request, the Camera acquires and then calculates some key values as the min, the max, the average or the standard deviation in this Region of Interest.

The grab and calculation command and also the collection of the results is not performed in real time as it is done through the serial connection.

This function and the results are available in CommCam in the “Line Profile Average” Section :



- **Line Profile average measurement (*LineAverageProfile*)** : Control the grab and computation of the statistics.
 - ⇒ Read function : “**r pixs**” : Get the status of the calculation
Returned by the camera : 0 : finished, 1: running
 - ⇒ Write function :
 - “**w rffc 1**” : Start the accumulation and then the computing
 - “**w rffc 0**” : Abort the computing.

The Calculated values are detailed as following :

- **Pixel average Value (*PixelROIMean*)** : Average gray level value calculated on whole Region of interest
 - ⇒ Read function : “**r pavr**” : Get the average value
Returned by the camera : Unsigned format value : U12.4
- **Pixel Standard deviation (*PixelROIStandardDeviation*)** : standard deviation of all the pixel gray level values of Region of interest
 - ⇒ Read function : “**r pstd**” : Get the standard deviation
Returned by the camera : Unsigned format value : U12.4
- **Pixel Min value (*PixelROIMin*)** : Minimum gray level pixel value on the whole region of interest.
 - ⇒ Read function : “**r pmin**” : Get the Minimum value
Returned by the camera : Unsigned format value : U12.4
- **Pixel Max Value (*PixelROIMax*)** : Maximum gray level pixel value on the whole region of interest
 - ⇒ Read function : “**r pmax**” : Get the maximum value
Returned by the camera : Unsigned format value : U12.4
- **Pixel access Line number (*PixelAccessLineNumer*)** : Set the number of lines to accumulate.
 - ⇒ Read function : “**r pixl**” : Get the number of line
Returned by the camera : 1, 256, 521 or 1024
 - ⇒ Write function : “**w pixl <val>**” : Set the number of lines. <val> is 1, 256, 512 or 1024.

- **Pixel ROI Start** (*PixelRoiStart*) : Set the Region of Interest start position.
 - ⇒ Read function : “**r prod**” : Get the starting pixel
Returned by the camera : value between 0 and SensorWidth-1
 - ⇒ Write function : “**w prod <val>**” : Set the starting pixel. <val> is between 0 and SensorWidth-1

- **Pixel ROI Width** (*PixelRoiWidth*) : Set the Width of the Region of Interest.
 - ⇒ Read function : “**r prow**” : Get the width in pixel
Returned by the camera : value between 1 and SensorWidth
 - ⇒ Write function : “**w prow <val>**” : Set the ROI width in pixels. <val> is between 1 and SensorWidth



After performing a line profile measurement, all the values computed which are described below are not refreshed automatically in CommCam : You have to right-click on each value and ask for an individual refresh.

8.10 Privilege Level

There are 3 privilege levels for the camera :

- Factory (0) : Reserved for the Factory
- Integrator (1) : Reserved for system integrators
- User (2) : For all Users.

The Cameras are delivered in Integrator mode. They can be locked in User mode and a specific password is required to switch back the Camera in Integrator mode. This password can be generated with a specific tool available from the hotline (hotline-cam@e2v.com)

This function is available in the Privilege section :



- **Privilege level Management** (*PrivilegeLevel*) : Get the current Camera privilege level..
 - ⇒ Read function : “**r lock**” : Get the current Tap Bank used
Returned by the camera : 0 to 2
 - ⇒ Write function : “**w lock <val>**” : <val> is as follow
 - **2** : Lock the Camera in Integrator or “privilege User”
 - **<computed value>** : Unlock the Camera back in Integrator mode

8.11 Save & Restore Settings

The settings (or Main configuration) of the Camera can be saved in 4 different User banks and one Integrator bank. This setting includes also the FFC and LUT enable

This function is available in the Save & Restore Settings section :



- **Load settings from Bank** : Allows to restore the Camera settings.
 - ⇒ Read function : “**r rcfg**” : Get the current Tap Bank in use
 - ⇒ Write function : “**w rcfg <val>**” : Load settings from bank <val> (0: Factory , 1 to 4 for User, 5 for Integrator)
- **Save settings to Bank** : Allows to save the Camera settings in User or Integrator Bank
 - ⇒ Write function : “**w scfg <val>**” : Save the current settings in the User bank <val> (1 to 4 for User, 5 for Integrator)



The integrator bank (5) can be written only if the Camera is set in integrator mode (Privilege level = 1). This integrator bank can be used as a « Factory default » by a system integrator.

APPENDIX

Appendix A. Test Patterns

A.1 Test Pattern 1 : Vertical wave

The Test pattern 1 is a vertical moving wave : each new line will increment of 1 gray level in regards with the previous one.

- In 12 bits the level reaches 4095 before switching down to 0
- In 10 bits the level reaches 1023 before switching down to 0
- In 8 bits the level reaches 255 before switching down to 0

A.2 Test Pattern 2 : In 8 bits format

A.1.2 512 Pixels

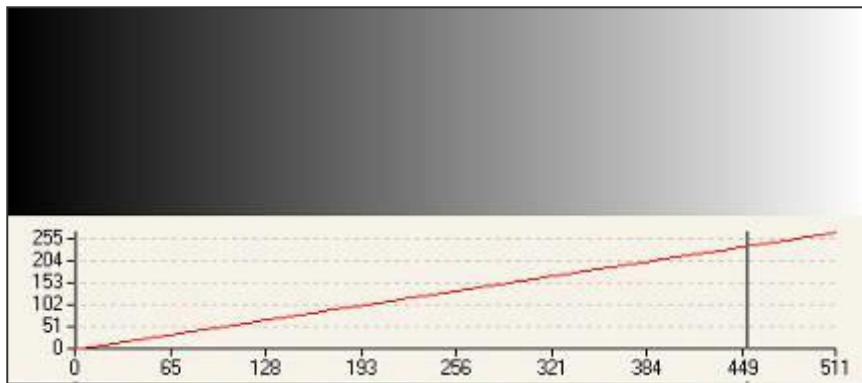

Pixel :	1	2	3	4	5	...	509	510	511	512
Value :	0	0	1	1	2	...	254	254	255	255

A.2.2 1024 Pixels

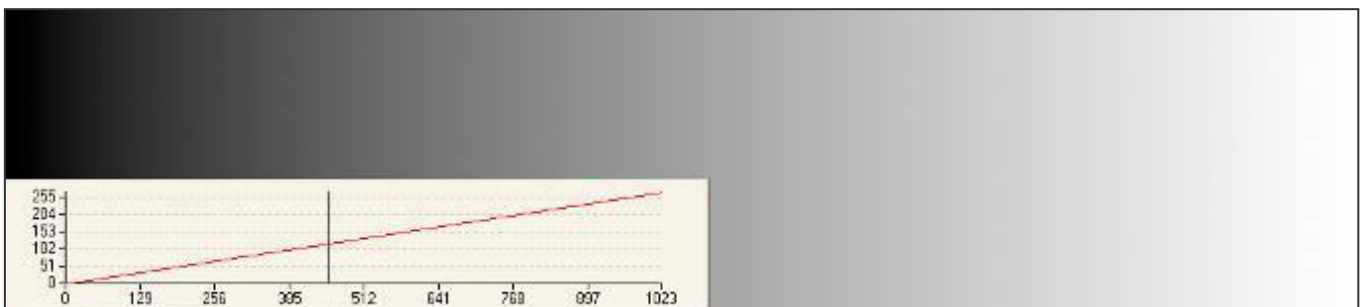

Pixel :	1	2	3	4	5	...	1020	1021	1022	1023	1024
Value :	0	0	0	0	1	...	254	255	255	255	255

A.3.2 2048 Pixels

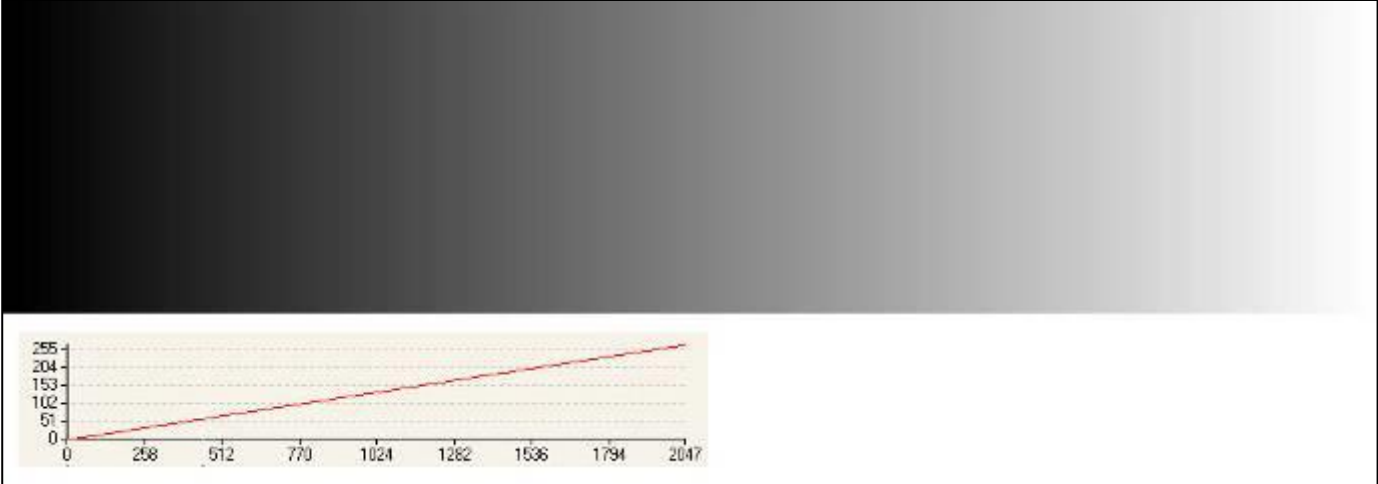

Pixel :	1	2	3	4	5	6	...	2044	2045	2046	2047	2048
Value :	0	0	1	1	2	2	...	1021	1022	1022	1023	1023

A.4.2 4096 Pixels

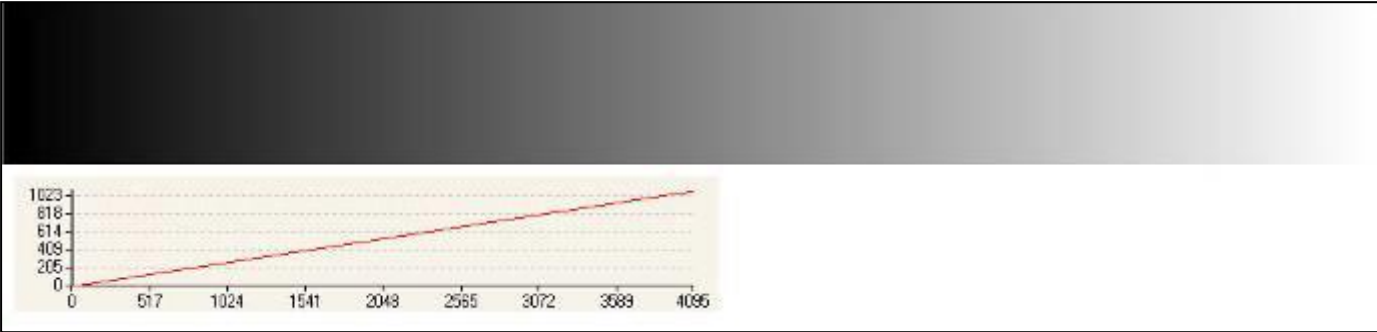

Pixel :	1	2	3	4	5	...	4092	4093	4094	4095	4096
Value :	0	0	0	0	1	...	1022	1023	1023	1023	1023

A.3 Test Pattern 2 : In 12 bits format

A.1.3 512 Pixels

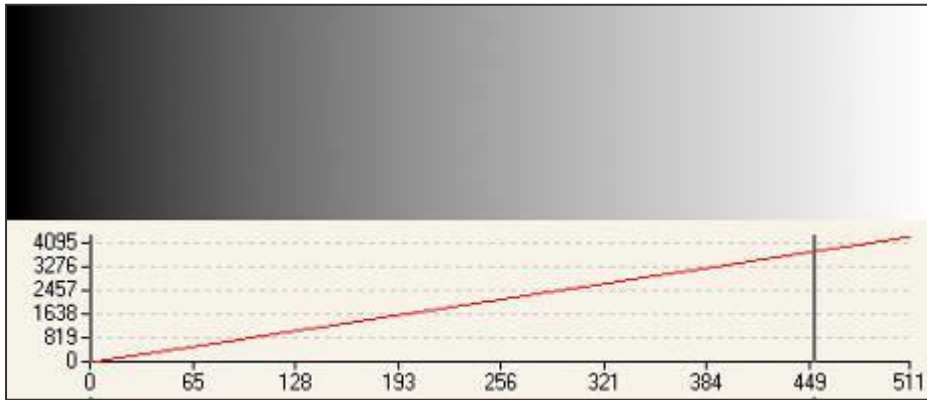

EM4

Pixel :	1	2	3	...	255	256	257	...	510	511	512
Value :	0	8	16	...	2040	2055	2063	...	4079	4087	4095

EM2

Pixel :	1	2	3	...	510	511	512
Value :	0	8	16	...	4072	4080	4088

A.2.3 1024 Pixels

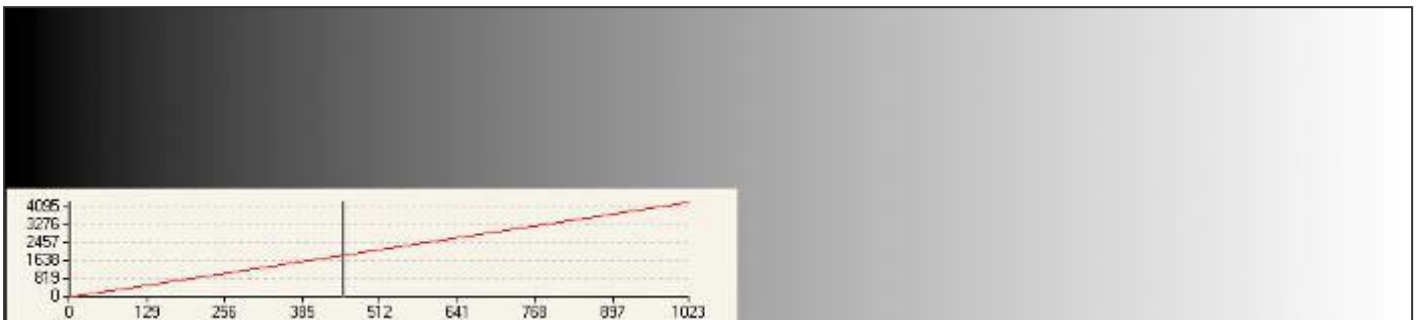

EM4

Pixel :	1	2	3	...	511	512	513	...	1022	1023	1024
Value :	0	4	8	...	2040	2044	2051	...	4077	4091	4095

EM2

Pixel :	1	2	3	...	1022	1023	1024
Value :	0	4	8	...	4084	4088	4092

A.3.3 2048 Pixels

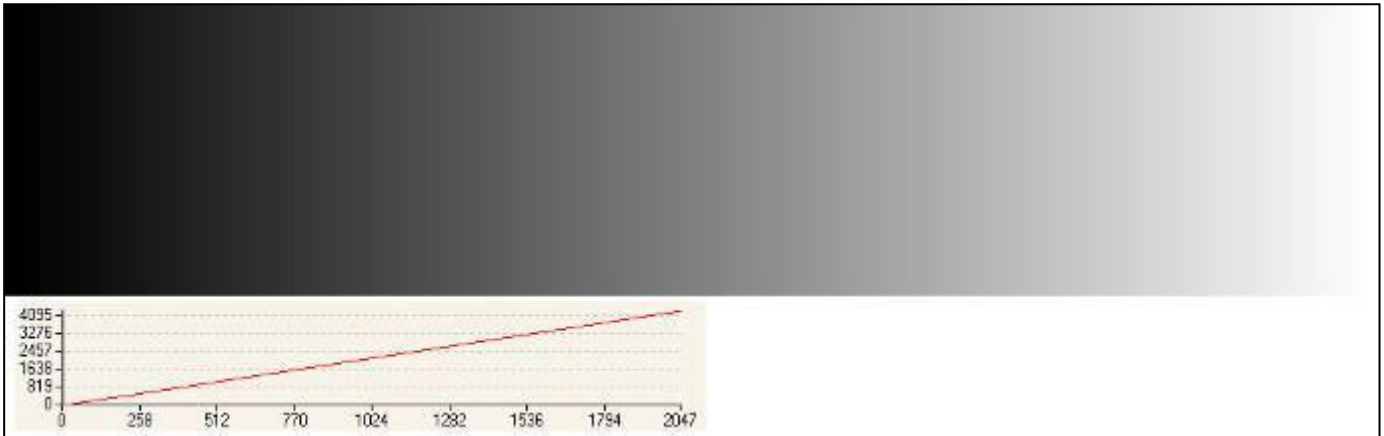

EM4

Pixel :	1	2	3	...	1024	1025	1026	...	2045	2046	2047	2048
Value :	0	2	4	...	2046	2049	2051	...	4089	4091	4093	4095

EM2

Pixel :	1	2	3	...	2045	2046	2047	2048
Value :	0	2	4	...	4089	4091	4093	4094

A.4.3 4096 Pixels

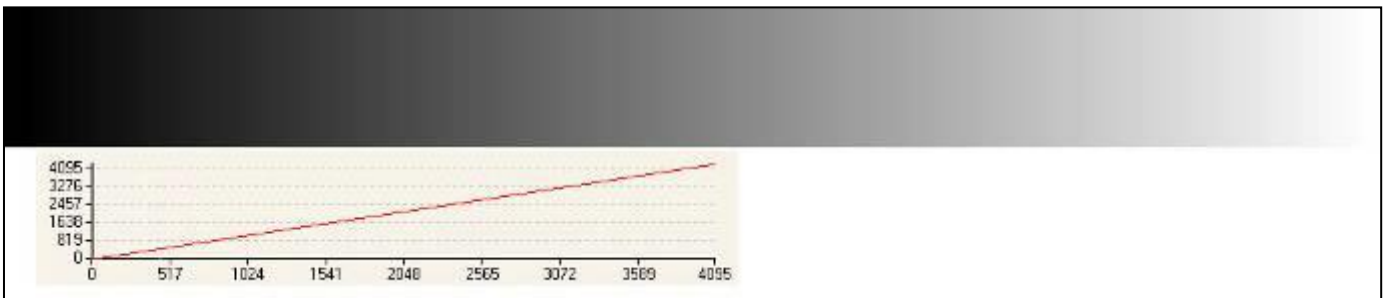

Pixel :	1	2	3	4	5	6	...	4092	4093	4094	4095	4096
Value :	0	1	2	3	4	5	...	4091	4092	4093	4094	4095

Appendix B. Thermal Management

B.1 Heat Sinks

The most important source of heat in the camera is around the sensor.

The EM4 Camera dissipates around 11W max with 4 taps at 40MHz (4K pixels version)

The Camera has been designed to dissipates the maximum of the internal heat through its front face : The packaging of the sensor is larger to increase the surface in contact with the front face and then improves the dissipation.

In the system, the camera has to be fixed by its front face with the largest contact possible with a metallic part.

Without any specific cooling system, a simple air flow around the camera will improve roughly the dissipation.

The EM4/EM2 Cameras are already delivered with 2 Heat Sinks, but if necessary, additional heat sinks are available (set of 2) and they can be fixed on any side of the front face :



Set of 2 x Heat Sinks : Part number AT71KFPAVIVA-CAA

One heat sink can decrease the temperature of the front face of about 5°C down.

B.2 Temperature dropping

Some measurements have been done to establish the dropping temperature steps between different control points :

- Ambient room temperature (burning room with controlled pulsed air)
- Front Face of the Camera
- Internal Temperature sensor (measure available with CommCam).

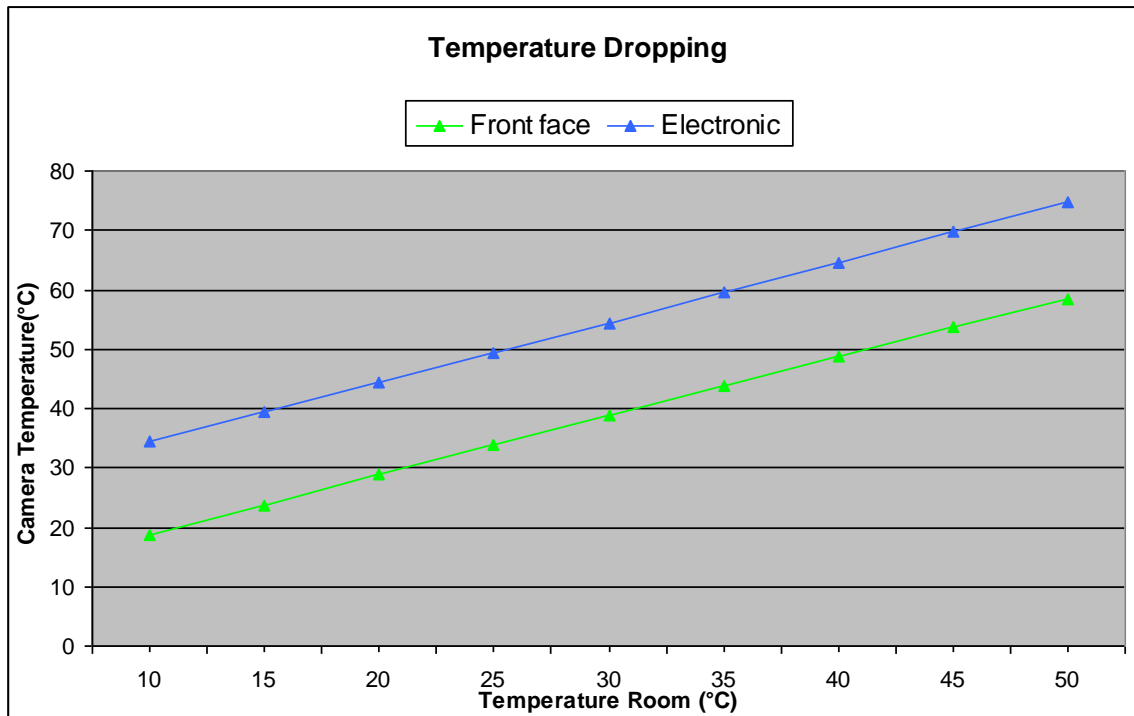

It has been established that the steps are the following (after a certain time) :

- Ambient room to Front Face about : **+ 10°C**
- Front Face to internal sensor about : **+ 15°C**

Then an average of **+ 25°C** between the room ambient temperature and the internal sensor.

The specification limits have been fixed at :

- 45°C for the ambient temperature
- 55°C for the Front Face
- 70°C internal Sensor.



The ambient temperature is necessary defined here as a pulsed air or with an air flow around the camera otherwise the temperature around the Camera is not homogeneous and can be much more important than the one measured in the room.

B.3 Performance curves versus Temperature

- These curves have been established with a 4k Pixel Camera (worst case).
- The “Camera Temperature” is given by the internal Sensor of the Camera.
- All the values in LSB are in 12 bits

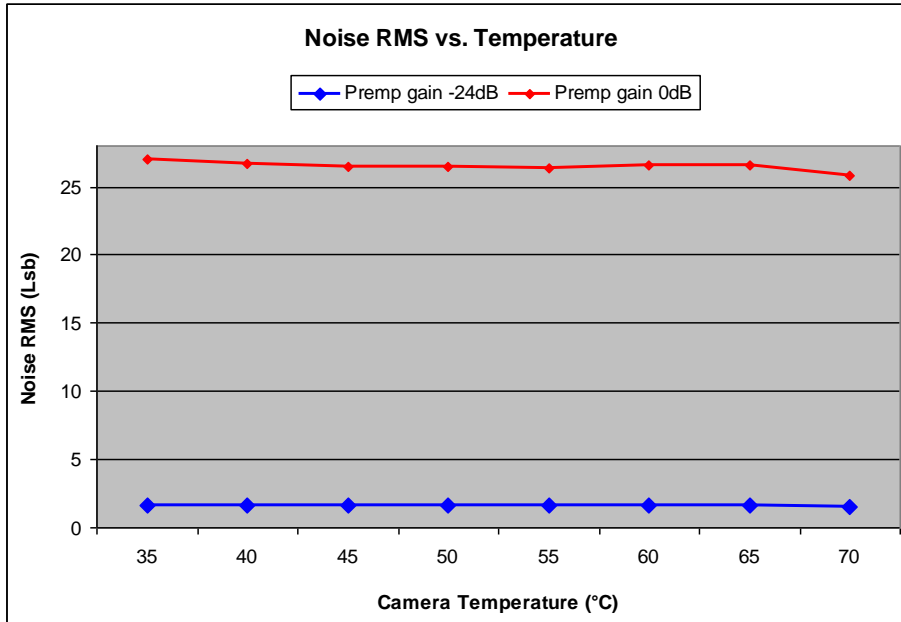

Noise vs Temperature : For both Min an Max preamp Gain values

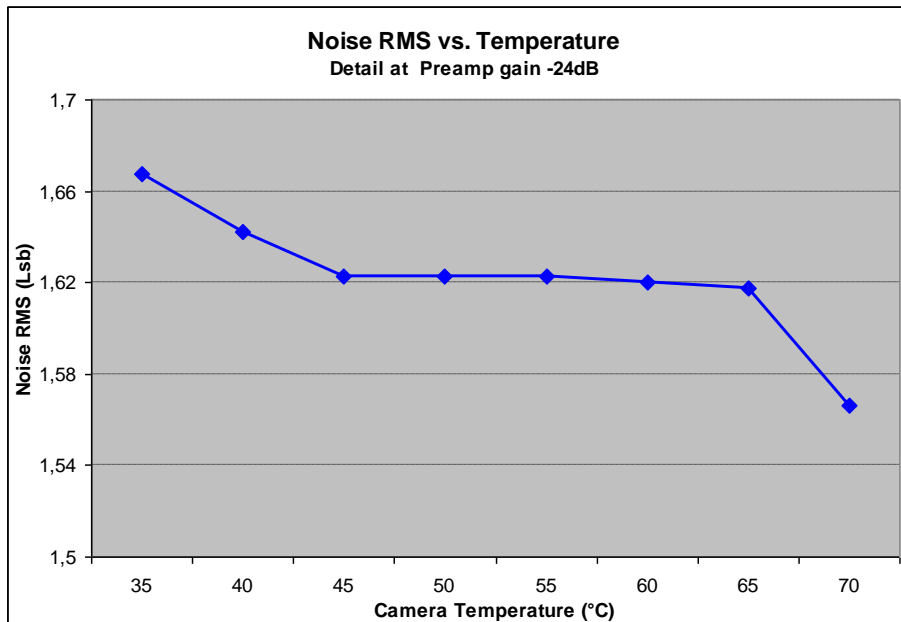

Noise vs Temperature : Detailed curve for the Min preamp Gain value



The Cameras tuning is done in factory after a certain time of warm up (close to a “normal condition of use) in order to ensure that the Camera will give its best while runing 24h a day. This explains a slight decreasing of the noise when the temperature rises up.

- The mean offset is the average value of the whole line of the sensor.
- The FPN peak to peak is the worst value for the whole line of the sensor.
- All the LSB values are in 12 bits

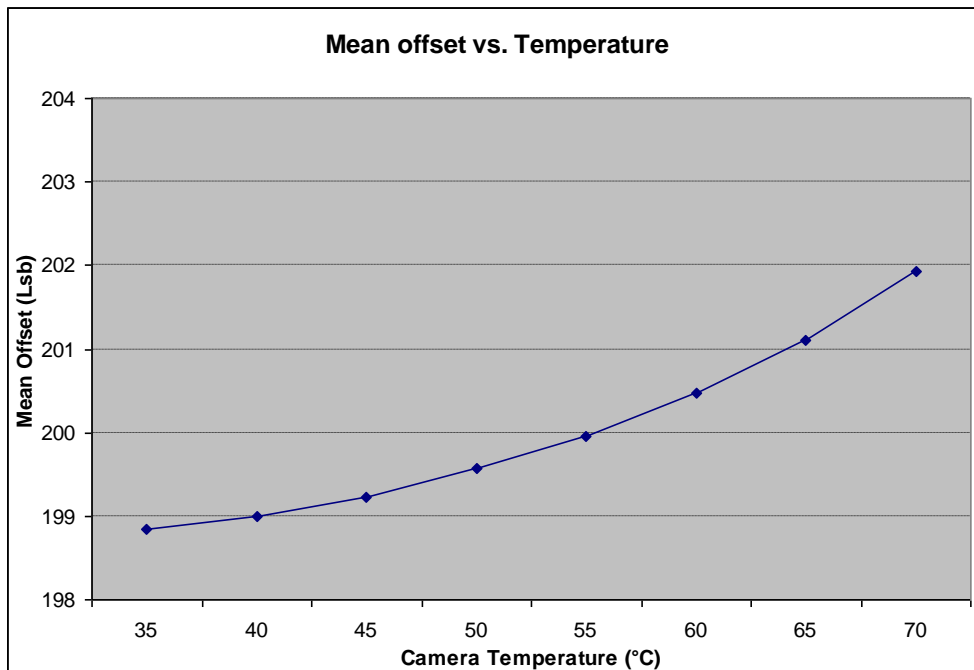

Average Offset vs Temperature : At min preamp Gain value (-24dB)

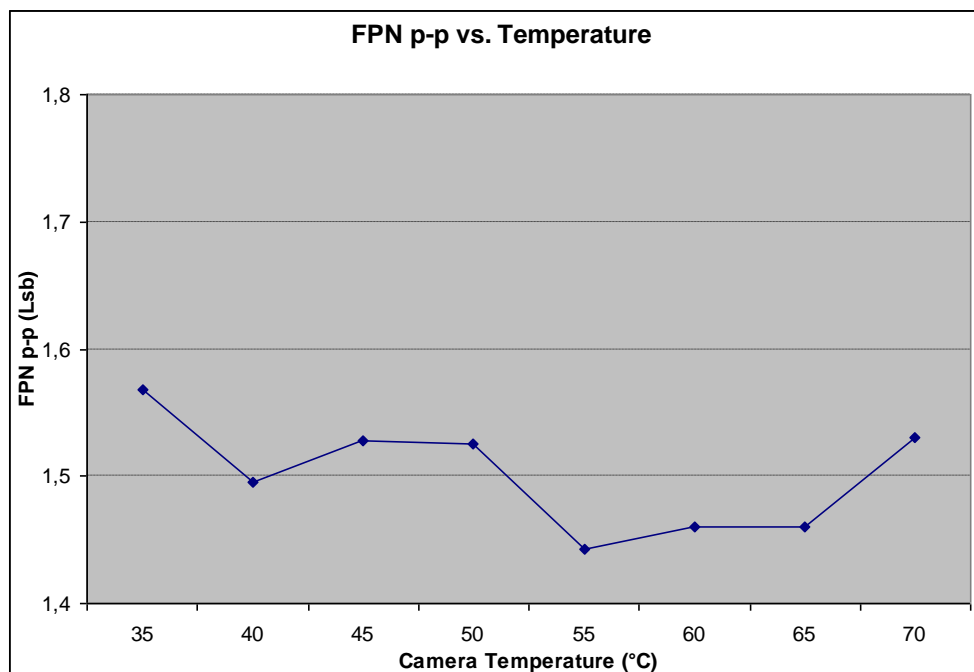

FPN peak-peak vs Temperature : At min preamp Gain value (-24dB)

Appendix C. Optical Mounts available

C.1 F-Mount



F Mount : Kit10 (Part number EV71KFPVIVA-ABA)

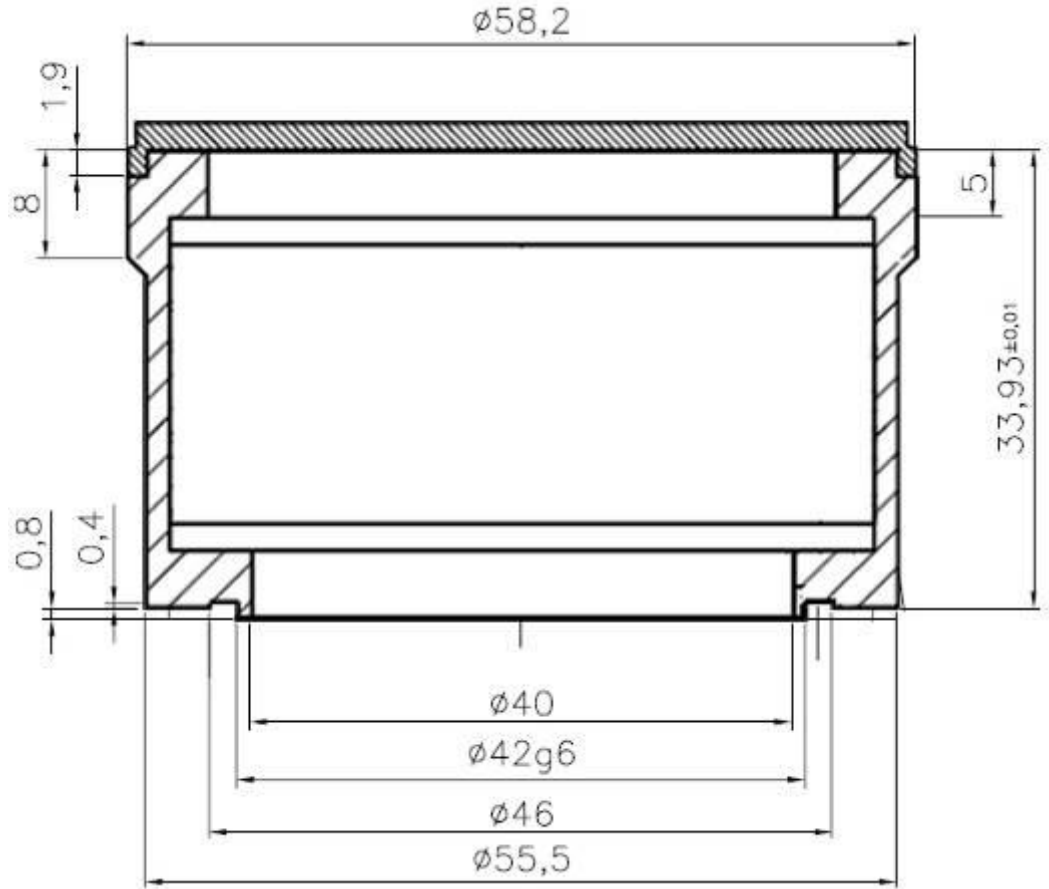

C.2 C-Mount



C Mount : Kit20 (Part number AT71KFPVIVA-ACA)

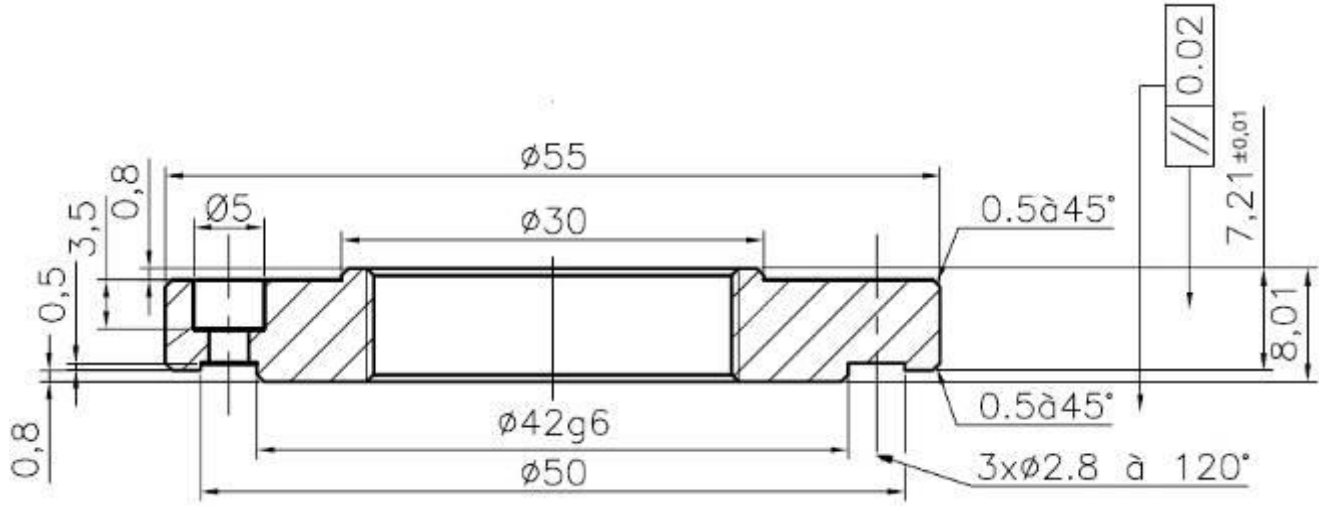

C.3 T2 & M42x1 Mounts



M42x0,75 (T2 Mount) : Kit30 (Part number AT71KFPVIVA-AKA)
 M42x1 Mount : Kit40 (Part number AT71KFPVIVA-ADA)

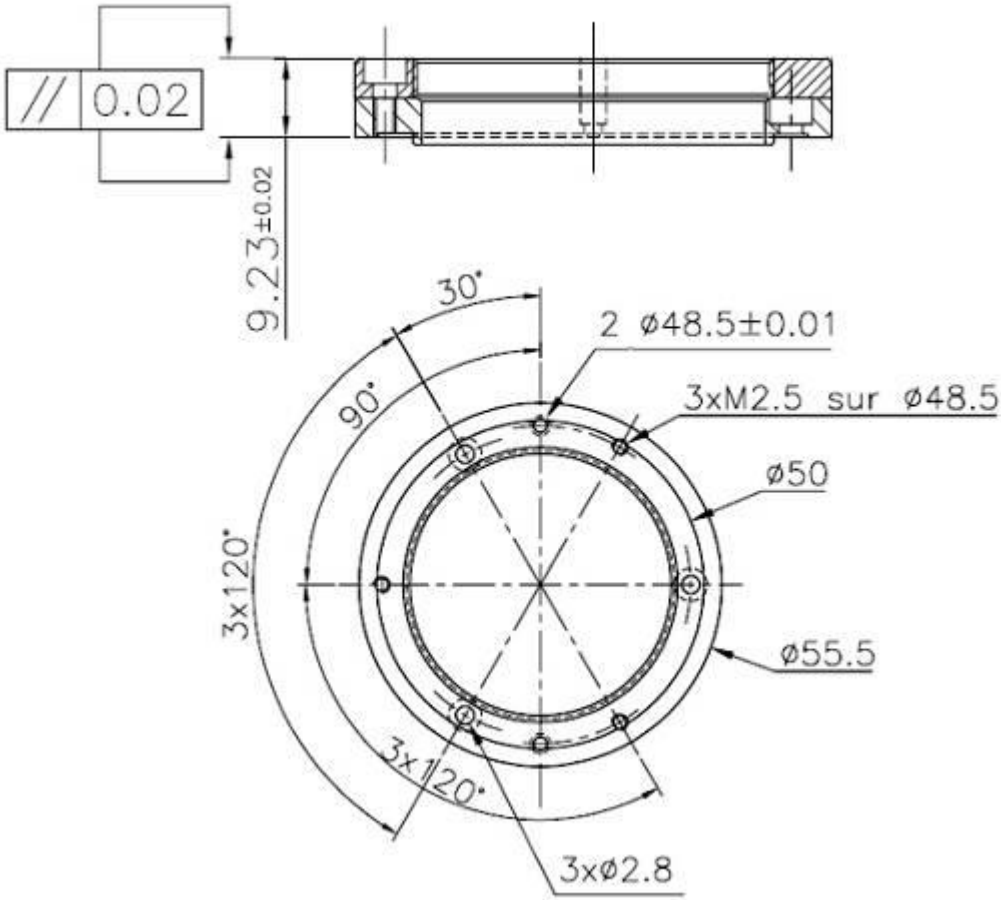

Appendix D. CommCam Connection

The Frame Grabber has to be compliant with Camera Link 1.1

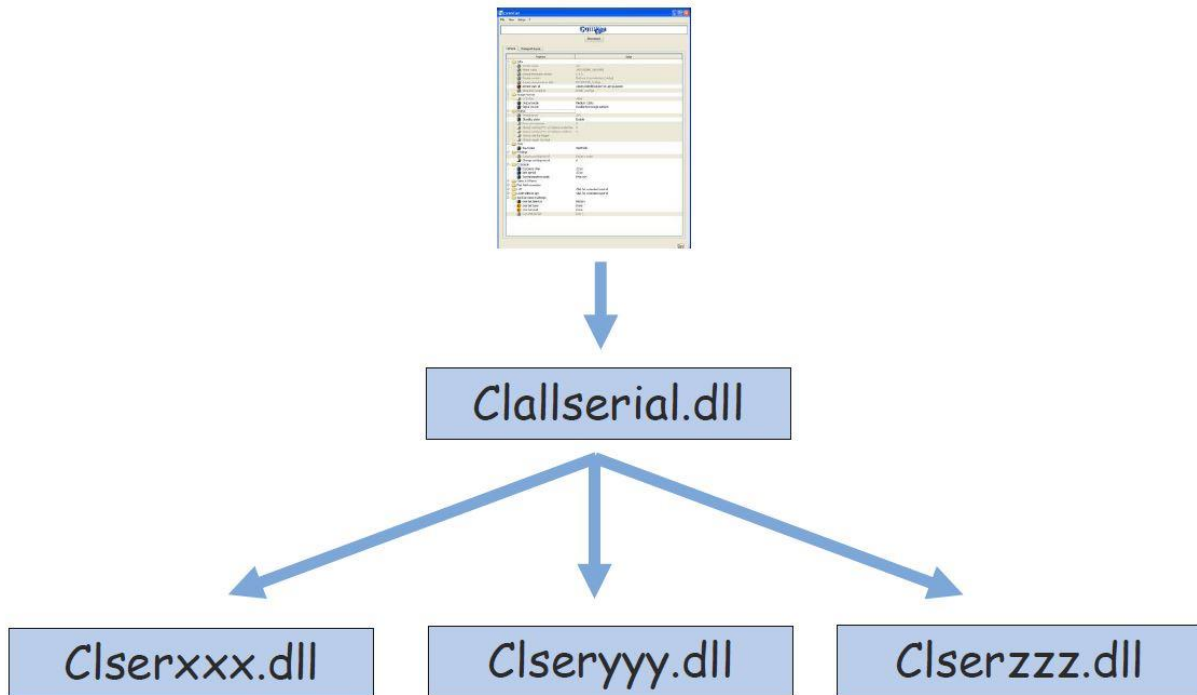



Clallserial.dll (Standard CameraLink Services Library)

- In 32bits : Must be located in : program files\CamerLink\serial and location added to PATH variable
- In 64bits : Must be located in : program files\CamerLink\serial or
 - For 32bits version : Must be located in : program files(x86)\CamerLink\serial and both locations added to PATH variable

Clserxxx.dll (FG Manufacturer dedicated CameraLink Services Library)

- **In 32bits** : in the directory defined by the Register Key :
CLSERIALPATH (REG_SZ) in HKEY_LOCAL_MACHINE\software\cameralink
The directory should be program files\CamerLink\serial or any other specified
- **In 64bits, for a 64bits version** : in the directory defined by the Register Key : CLSERIALPATH (REG_SZ) in HKEY_LOCAL_MACHINE\software\cameralink
The directory should be program files\CamerLink\serial or any other specified
- **In Windows 64bits, for a 32bits version** : in the directory defined by the Register Key : CLSERIALPATH (REG_SZ) in HKEY_LOCAL_MACHINE\Wow6432Node\software\cameralink
The directory should be program files(x86)\CamerLink\serial or any other specified

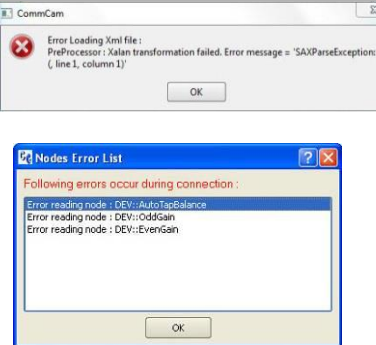
Defect	Detail	Solutions
<p><u>CommCam Can't find the Camera :</u> After launching CommCam, the Icon of the Camera is not visible.</p>		<ul style="list-style-type: none"> ■ The Camera is not powered up or the boot sequence is not finished. ■ The CameraLink cable is not connected or connected on the bad connector. ■ Check if the CameraLink libraries (cll1serial.dll and clserXXX.dll) are in the same directory (either <i>system32</i> or <i>program files/cameralink/serial</i>) ■ The Frame Grabber is compliant with CameraLink standard 1.1 <ul style="list-style-type: none"> > Contact the hotline : hotline-cam@e2v.com
<p><u>An e2v Camera is detected but not identified :</u> A “question Mark” icon appears in place of the one of the AVIIVA2</p>		<ul style="list-style-type: none"> ■ The version of CommCam used is too old : You have to use the version 1.2.x and after.
<p><u>Impossible to connect to the identified Camera :</u> The message “Impossible to open device” is displayed</p>		<ul style="list-style-type: none"> ■ There is a possible mismatch between the major version of xml file used by CommCam and the firmware version of the Camera ■ Possible Hardware error or Camera disconnected after being listed. <ul style="list-style-type: none"> > Contact the hotline : hotline-cam@e2v.com
<p><u>Error messages is displayed just after/before the connection :</u></p>		<ul style="list-style-type: none"> ■ There is a possible mismatch between the minor version of xml file used by CommCam and the firmware version of the Camera ■ Default values of the Camera out of range <p>Contact the hotline : hotline-cam@e2v.com</p>

Appendix E. COMMAND SUMMARY

E.1 Information

Feature (GenlCam)	CL Command	Description
(DeviceVendorName)	r vdnm	Get camera vendor name as a string (32 bytes long including '\0')
(DeviceModelName)	r mdnm	Get camera model name as a string (32 bytes long including '\0')
(DeviceFirmwareVersion)	r dfvw	Get camera synthetic firmware version (PKG version) as a string (16 bytes long including '\0')
(DeviceVersion)	r dhvw	Get camera version as a string (hardware version) (32 bytes long including '\0')
(DeviceManufacturerInfo)	r idnb	Get camera ID as a string (128 bytes long including '\0')
(DeviceUserID)	r cust	Get device user identifier as a string (128 bytes long including '\0')
	w cust <idstr>	Set camera identifier to <idstr>
(ElectronicBoardID)	r boid	Read Electronic Board ID

E.2 Dump and Communication

Feature (GenlCam)	CL Command	Description
Dump		Available in CommCam only
(Baudrate)	w baud 1	Set CL RS232 baudrate to 9600Bds (always boot with 9600bds)
	w baud 2	Set CL RS232 baudrate to 19200Bds
	w baud 6	Set CL RS232 baudrate to 57600Bds
	w baud 12	Set CL RS232 baudrate to 115200Bds
	r baud	Get current baud rate

E.3 Standby, Temperature and Status

Feature (GenlCam)	CL Command	Description
Internal Temp. sensor (Temperature)	r temp	Read internal temperature (format signed Q10.2 = signed 8 bits, plus 2 bits below comma. Value from -512 to +511) in °C
Standby mode (Standby)	r stby	Read Standby state
	w stby 0	Disable standby mode ("False")
	w stby 1	Enable standby mode ("True"), no more video available but save power and temperature
Camera Status Register	r stat	Get camera status
(StatusWaitForTrigger)		Bit 0: true if camera waits for a trigger during more than 1s
(StatusTriggerTooFast)		Bit 1: true if camera trigger is too fast
(StatusWarningOverflow)		Bit 8: true if a an overflow occurs during FFC calibration or Tap balance
(StatusWarningUnderflow)		Bit 9: true if a an underflow occurs during FFC calibration or Tap balance
(StatusErrorHardware)		Bit 16 : true if hardware error detected

E.4 Image Format

Feature (GenICam)	CL Command	Description
CCD Width (SensorWidth)	r ccdz	Integer : 512 to 4096
Signal Source (TestImageSelector)	w srce 0	Set signal source to CCD sensor
	w srce 1	Set signal source to user pattern 1
	w srce 2	Set signal source to user pattern 2
	r srce	Get current signal source
(OutputMode)	w mode 0	4 x 40MHz 8 bits EM4 only
	w mode 1	4 x 40MHz 10 bits EM4 only
	w mode 2	4 x 40MHz 12 bits EM4 only
	w mode 3	2 x 40MHz (EM2) or 80MHz (EM4) in 8 bits
	w mode 4	2 x 40MHz (EM2) or 80MHz (EM4) in 10 bits
	w mode 5	2 x 40MHz (EM2) or 80MHz (EM4) in 12 bits
	r mode	Get current output mode

E.5 Exposure and Synchronization

Feature (GenICam)	CL Command	Description
Synchronisation Mode (SynchroMode)	w sync 0	Set free run mode, with integration time and line period programmable
	w sync 1	Set line period synchronisation with integration time programmable
	w sync 2	Set line period synchronisation (start and period) with integration time to its maximum
	w sync 3	Set line period synchronisation (start and period) and integration time controlled by 1 signal (ITC)
	w sync 4	Set line period synchronisation (start and period) and integration time controlled by 2 signals
	r sync	Get current synchronisation mode
Integration time (ExposureTimeAbs)	w tint <val>	Set integration time to <val> x100ns, from 1 to 65535
	r tint	Get current integration time
Line Period (LinePeriod)	w tper <val>	Set line period to <val> x100ns, from 1 to 65535 Disabled if tper < tint
	r tper	Get current line period

E.6 Gain and Offset

Feature (GenICam)	CL Command	Description
Preamp gain (GainAbs with GainSelector = AnalogAll)	w pamp <val>	Set pre amplifier gain to: 0 (-24dB), 1 (-18dB), 2 (-12dB), 3 (-6dBdB), 5 (0dB) (analog gain) Change Tap balance settings to factory default
	r pamp	Get current pre amplifier
GAIN (GAINAbs WITH GAINSELECTOR = GAINAll)	w gain <val>	Set gain form 0 (0) to +8dB (6193) Gain(dB) = 20.log (1+Gain/4096)
	r gain	Get current gain
Tap Offset Balance (BlackLevelAutoBalance)	w balo 1	Start offset tap balance; OnePush button (auto disable once finished)
	w balo 0	Stop offset tap balance
	r balo	Get the offset tap balance status (1 for running, 0 for finished)
Tap Gain Balance (GainAutoBalance)	w balg 1	Start gain tap balance; OnePush button (auto disable once finished)
	w balg 0	Stop gain tap balance
	r balg	Get the gain tap balance status (1 for running, 0 for finished).
Digital Gain (GainAbs with GainSelector = DigitalAll)	w gdig <val>	Set digital gain from 0 to 255 (20log(1+val/64) dB)
	r gdig	Get digital gain
Digital Offset (BlackLevelRaw with BlackLevelSelector = All)	w offs <val>	Set global offset from -4096 to +4095 in 12bits LSB (numeric offset)
	r offs	Get global offset
Tap1 Gain (GainAbs GainSelector = DigitalTap1)	r fga1	Get tap 1 Digital gain. Dynamically updated on AnalogAll gain changes
	w fga1 <val>	Set tap 1 digital gain from -128 to 127by step 1 (0.0021dB).
Tap2 Gain : (GainAbs GainSelector = DigitalTap2)	r fga2	Get tap 2 Digital gain. Dynamically updated on AnalogAll gain changes
	w fga2 <val>	Set tap 2 digital gain from -128 to 127 by step 1 (0.0021dB).
Tap3 Gain : EM4 only (GainAbs GainSelector = DigitalTap3)	r fga3	Get tap 3 Digital gain. Dynamically updated on AnalogAll gain changes
	w fga3 <val>	Set tap 3 digital gain from -128 to 127 by step 1 (0.0021dB).
Tap4 Gain : EM4 only (GainAbs GainSelector = DigitalTap4)	r fga4	Get tap 4 Digital gain. Dynamically updated on AnalogAll gain changes
	w fga4 <val>	Set tap 4 digital gain from -128 to 127 by step 1 (0.0021dB).
Tap1 Offset (BlackLevelRaw BlackLevelSelector = Tap1)	r off1	Get tap 1 black level. Dynamically updated on All BlackLevel changes
	w off1 <val>	Set tap 1 black level from -128 to 127, step 1
Tap2 Offset (BlackLevelRaw BlackLevelSelector = Tap2)	r off2	Get tap 2 black level. Dynamically updated on All BlackLevel changes
	w off2 <val>	Set tap 2 black level from -128 to 127, step 1
Tap3 Offset : EM4 only (BlackLevelRaw BlackLevelSelector = Tap3)	r off3	Get tap 3 black level Dynamically updated on All BlackLevel changes
	w off3 <val>	Set tap 3 black level from -128 to 127, step 1
Tap4 Offset : EM4 only (BlackLevelRaw BlackLevelSelector = Tap4)	r off4	Get tap 4 black level. Dynamically updated on All BlackLevel changes
	w off4 <val>	Set tap 4 black level from -128 to 127, step 1

E.7 Flat Field Correction

Feature (<i>GenICam</i>)	CL Command	Description
FFC Correction (<i>FFCEnable</i>)	w ffc 0	Disable Flat Field Correction processing
	w ffc 1	Enable Flat Field Correction processing
	r ffc	Get Flat Field Correction processing status
FPN User Calibration (<i>FPNCalibrationCtrl</i>)	w calo 1	Start FPN user calibration; OnePush button (auto disable once finished)
	w calo 0	Stop FPN user calibration
	r calo	Get the FPN user calibration status
PRNU User Calibration (<i>FFCCalibrationCtrl</i>)	w calg 1	Start PRNU user calibration for all Lines; OnePush button (auto disable once finished)
	w calg 0	Stop PRNU user calibration
	r calg	Get the PRNU user calibration status
FPN Reset (<i>FPNReset</i>)	w rsto 0	Clear FPN coefficients to 0
PRNU Reset (<i>PRNUReset</i>)	w rstg 0	Set PRNU coefficients to 1
FFC user bank save/load (<i>RestoreFFCFromBank</i>) (<i>SaveFFCToBank</i>)	w sffc <val>	Save current user FFC (FPN & PRNU) into FFC bank number <val>. <val> between 1 and 4
	w rffc <val>	Load current user FFC from FFC bank number <val>. <val> between 0 and 4 0 is a virtual bank that reset ffc coefficients
	r rffc	Get the current user FFC bank used (saved or loaded)
FPN user coefficients	w ffco <addr> <val>	Write 128 consecutive FPN user coefficients starting from the <addr> address. <val> is the concatenation of individual FPN values, without space between the values (one unsigned short per coefficient).
	r ffco <addr>	Read 128 consecutive FPN user coefficients starting from <addr> address. Returned value is in hexadecimal, without space between values (one unsigned short per coefficient).
PRNU user coefficients	w ffcg <addr> <val>	Write 128 consecutive PRNU user coefficients starting from the <addr> address. <val> is the concatenation of individual PRNU values, without space between the values (one unsigned short per coefficient).
	r ffcg <addr>	Read 128 consecutive PRNU user coefficients starting from <addr> address. Returned value is in hexadecimal, without space between values (one unsigned short per coefficient).

E.8 Look up Table

Feature(<i>GenICam</i>)	Commands	Description
<i>(LUTEnable)</i>	r lute	Get LUT status
	w lute 0	Disable LUT ("False")
	w lute 1	Enable LUT ("True")
LUT Values	r lutc <addr>	Read 128 LUT coefficients starting from address <addr> from 0 to 4095-128. Return value is in hexadecimal, without space between values. (one unsigned short per coef)
	w lutc <addr> <val>	Write 128 LUT coefficients starting from address <addr> form 0 to 4095-128. <val> is the concatenation of individual LUTvalue, without space between values.

E.9 Statistics and Line Profile

Feature (<i>GenICam</i>)	CL Command	Description
<i>(LineAverageProfile)</i>	r pixs	Get the line Line Average Profile status 1 : running 0 : finished
	w pixs 0	Abort the Line Average Profile
	w pixs 1	Run the Line Average Profile
<i>(PixelAccessLineNumber)</i>	r pixl	Get the number of line for average
	w pixl <val>	Set the number of line to accumulate - <val> : 1,256,512,1024
Pixels values	r pixv <addr>	Read 128 pixel values starting from address <addr>, from SensorWidth-128-1. Return value is in hexadecimal, without space between values. (one unsigned short per coef)
<i>(PixelRoiStart)</i>	r prod	Get Roi start
	w prod <val>	Set Roi start for pixel statistic computing (0 to SensorWidth -1)
<i>(PixelRoiWidth)</i>	r prow	Get Roi width
	w prow <val>	Set Roi width for pixel statistic computing (1 to SensorWidth)
(PixelROI Mean)	r pavr	Get ROI Mean (format U12.4)
(PixelROI StandardDeviation)	r pstd	Get ROI Standard deviation (format U12.4)
(PixelROI Min)	r pmin	Get ROI Min (format U12.4)
(PixelROI Max)	r pmax	Get ROI Max (format U12.4)

E.10 Privilege Level

Feature (GenlCam)	CL Command	Description
(PrivilegeLevel)	r lock	Get camera running privilege level 0 = Privilege Factory 1 = Privilege Advanced User 2 = Privilege User
(ChangePrivilegeLevel)	w lock 2	Lock camera privilege to "User"
	w lock <val>	Unlock camera privilege depending on <val> (min=256; max=232-1)

E.11 Save & Restore Settings

Feature (GenlCam)	CL Command	Description
Load Camera Settings (UserSetLoad)	w rcfg <val>	Load configuration from bank number <val>. <val> between 0 and 5 0 is factory settings and 5 is Integrator bank.
	r rcfg	Get the current Bank number in use
Save Camera Settings (UserSetSave)	w scfg <val>	Save current configuration in User bank number <val>. <val> between 1 and 4
	w scfg 5	Save current configuration in integrator bank (5). Only if privilege is set to 1

Appendix F. Revision History

Manual Revision	Comments / Details	Firmware version		1 st CommCam compliant Version
Rev A	First release	EM4 4010 BA0	1.0.3C	1.2.2.x
		EM4 2014 BA0	1.0.2C	
		EM4 2014 BA9	1.0.3C	
		EM4 2010 BA9	1.0.2C	
		EM2 4010 BA0	-	
		EM2 2014 BA0	-	
		EM2 2014 BA9	-	
		EM2 2010 BA9	-	
Rev B	EM2 release. Doc correction : BA9 line rates. CommCam 1.2.5 needed for some Frame Grabbers	EM4 4010 BA0	1.0.4B	1.2.5.x
		EM4 2014 BA0	1.0.3B	
		EM4 2014 BA9	1.0.4B	
		EM4 2010 BA9	1.0.3B	
		EM2 4010 BA0	1.0.2A	
		EM2 2014 BA0	1.0.2A	
		EM2 2014 BA9	1.0.2A	
		EM2 2010 BA9	1.0.2A	
Rev C	EM2/EM4 new sensor : 1k 14µm and 512 14µm	EM4 4010 BA0	1.0.4B	1.2.7.x
		EM4 2014 BA0	1.0.3B	
		EM4 2014 BA9	1.0.4B	
		EM4 2010 BA9	1.0.3B	
		EM2 4010 BA0	1.0.2A	
		EM2 2014 BA0	1.0.2A	
		EM2 2014 BA9	1.0.2A	
		EM2 2010 BA9	1.0.2A	
		EM2 1014 BA0	1.0.0A	
		EM4 1014 BA0	1.0.0A	
		EM2 1014 BA9	1.0.0A	
		EM4 1014 BA9	1.0.0A	
		EM4 0514 BA0	-	
		EM4 0514 BA0	-	
Rev D	EM2/EM4 new sensor : 1k 14µm and 512 14µm - Test Patterns - Characterization Values - C Mount details - New CommCam 2.x	EM4 4010 BA0	1.0.4C	2.0.2
		EM4 2014 BA0	1.0.3E	
		EM4 2014 BA9	1.0.5B	
		EM4 2010 BA9	1.0.5B	
		EM2 4010 BA0	1.0.2B	
		EM2 2014 BA0	1.0.2B	
		EM2 2014 BA9	1.0.3B	
		EM2 2010 BA9	1.0.3B	
		EM2 1014 BA0	1.0.0A	
		EM4 1014 BA0	1.0.0A	
		EM2 1014 BA9	1.0.0A	
		EM4 1014 BA9	1.0.0A	
		EM4 0514 BA0	1.0.0A	
		EM4 0514 BA0	1.0.0A	
Rev E / F	Minor corrections in documentation and New Template	NA		NA